



# N1505-1 Alternator / N3135 Regulator

## OEM Wiring Connections - Dual or Single Voltage Installation Instructions

### DUAL VOLTAGE (28 V/14 V) applications (see other side for single voltage):

1. Connect as shown on this page.

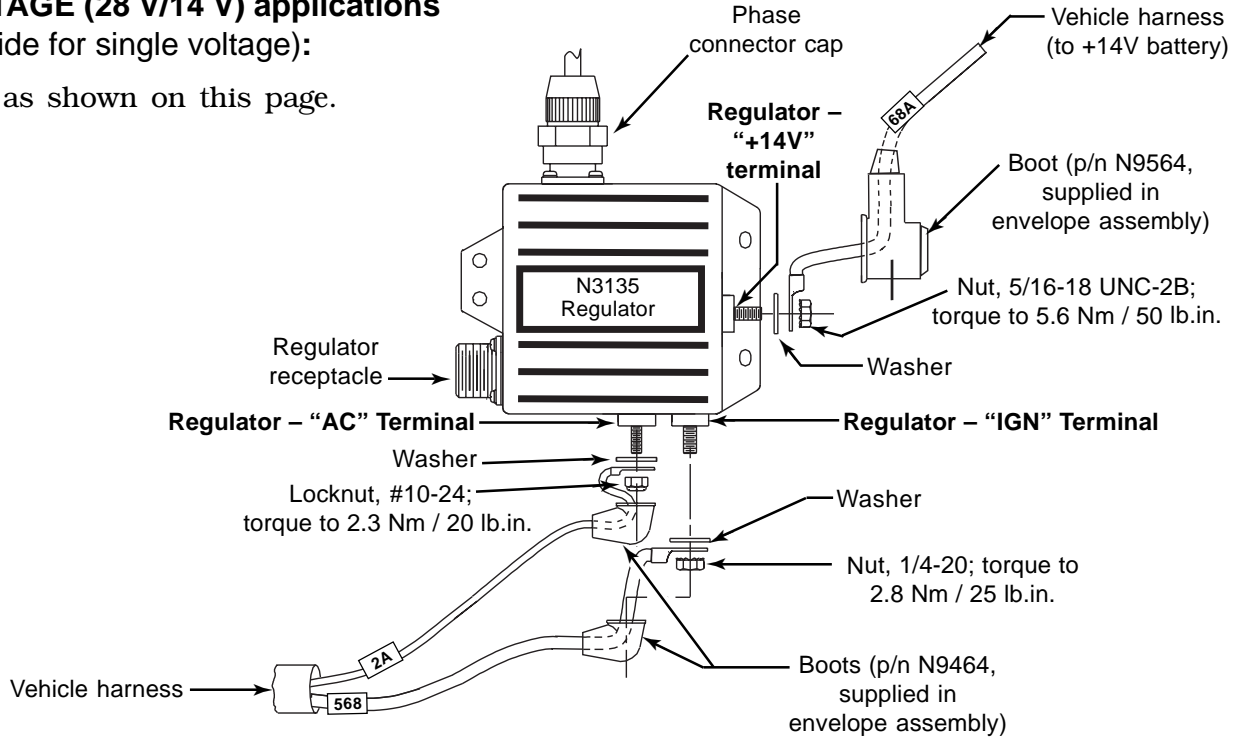

Figure 1a – N3135 Regulator **Dual Voltage** Wiring Connections

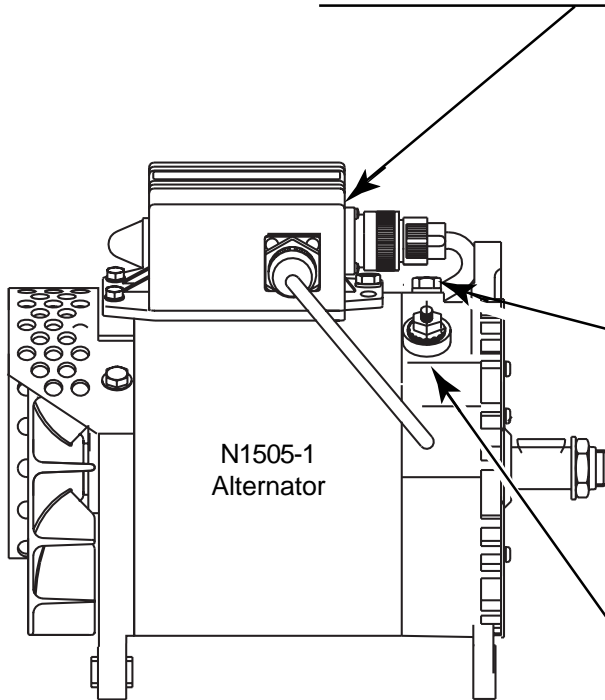

Figure 1 – N1505-1 Alternator

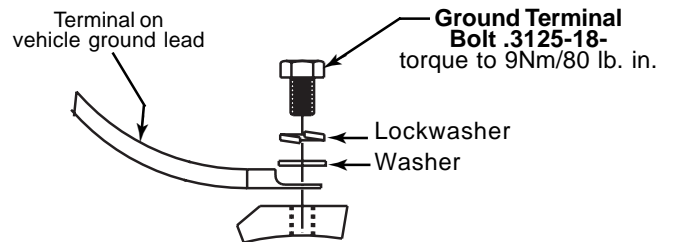

Figure 1b – Ground Terminal Connections

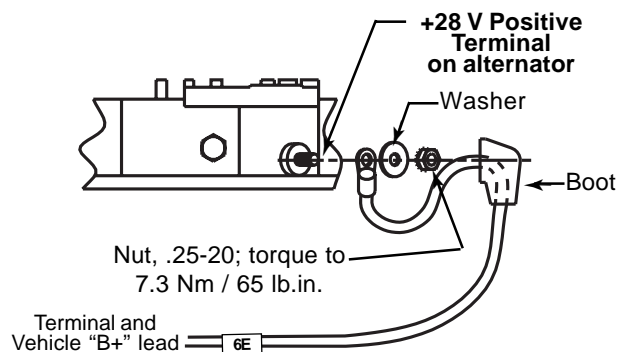

Figure 1c – Positive Terminal Connections

**SINGLE VOLTAGE (28 V) applications** (see other side for dual voltage):

1. Connect as shown on this page.

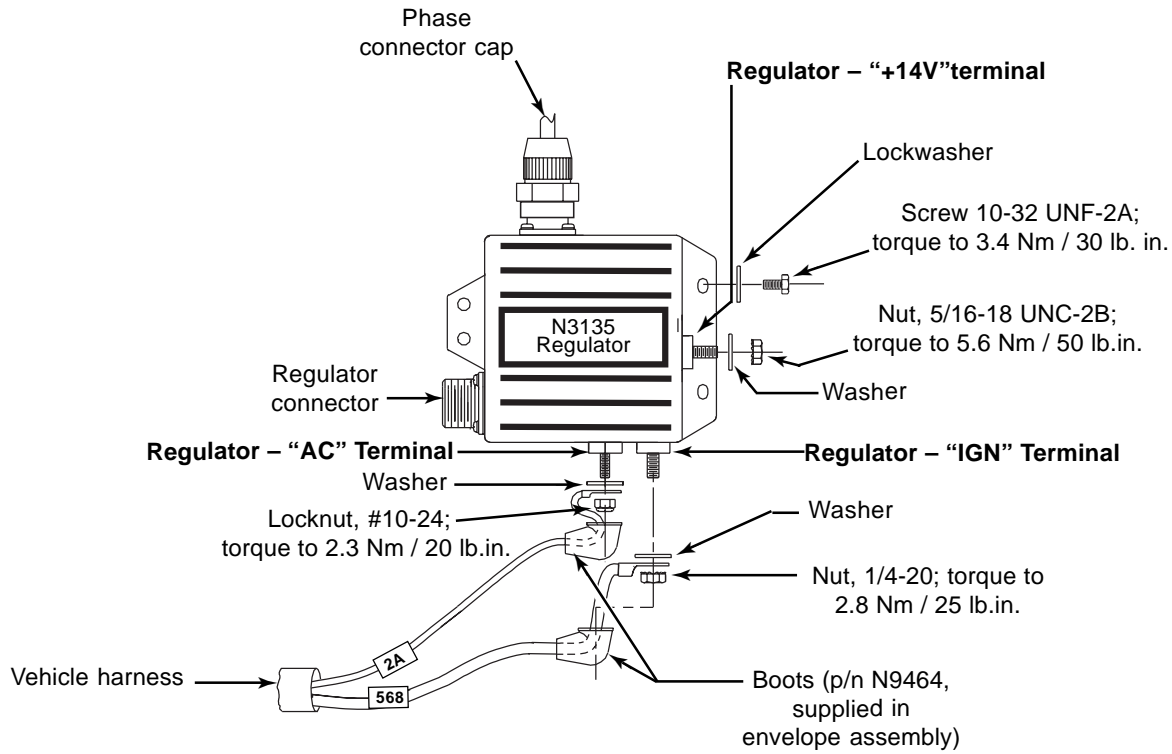

Figure 1a – N3135 Regulator **Single Voltage** Wiring Connections

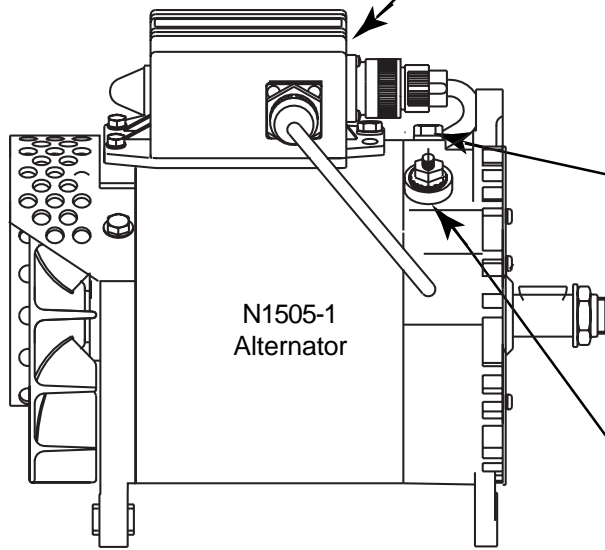

Figure 1 – N1505-1 Alternator

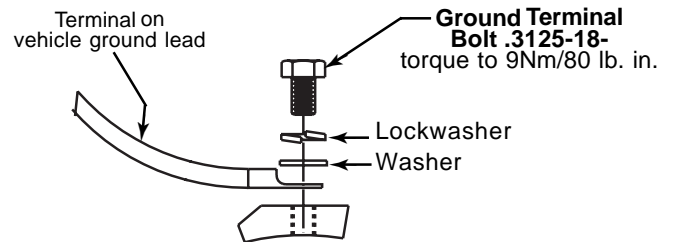

Figure 1c – Ground Terminal Connections

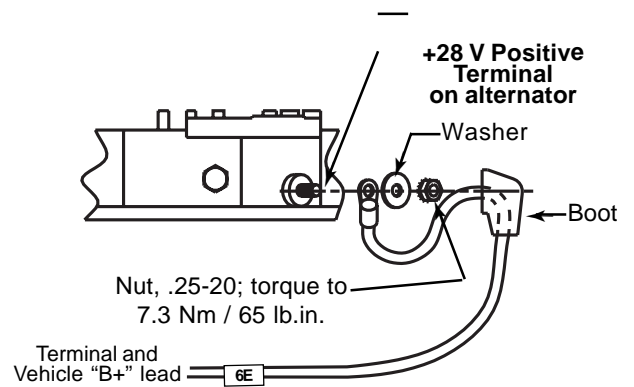

Figure 1b – Positive Terminal Connections