



CAUTION

This symbol is used to indicate presence of hazards that can cause minor property damage.

1. Install alternator as shown in Figure 1:

CAUTION

Slip bushing located in rear mounting foot must be securely tightened against alternator mounting bracket on engine. Failure to do so can result in broken mounting feet or broken upper mounting bracket.

- a. Use hardened washers between aluminum surfaces and bolt heads and nuts.
 - b. C656/C657/C658 OEM units are shipped with pulley, Belleville washer, and nut installed. C627/C628 OEM units are shipped with pulley, flat washer, and locknut installed.
 - c. C656/C657/C658 aftermarket units are shipped with shaft collar, Bellville washer, and nut installed. C627/C628 aftermarket units are shipped with pulley, flat washer, and locknut installed. Remove and discard shaft collar. Install pulley and furnished washer. Torque furnished hardware to 163 Nm/120 lb. ft.
 - d. Follow vehicle manufacturer's recommendations for belt tension.
2. All cabling, wiring or conduit must be supported within 305 mm/12 in. of termination on alternator.

3. Choose wire gauge capable of handling maximum alternator output with no more than 0.2 V drop on each leg from alternator to battery.
4. Regulator is furnished on OEM units and is supplied separately by request with aftermarket units. Mounting screws on regulator should be torqued to 8.5 Nm/75 lb. in.
5. A2-155 regulator connections:
 - Plug alternator-to-regulator harness into regulator.
 - Connect IGN terminal to ignition source through existing switch. Torque M5 terminal nut on regulator to 4.5 Nm/40 lb. in.
 - Connect P terminal to tachometer or relay. P terminal taps AC voltage, typically half the charge voltage. Torque M6 terminal nut on regulator to 4.5 Nm/40 lb. in.
6. A2-149 regulator connections:
 - Plug alternator-to-regulator harness into regulator.
 - Connect D+ terminal: D+ terminal provides 14 VDC voltage output to multiplex controller. When connecting D+ terminal to controller through a relay, the relay coil must be diode protected and rated for proper voltage. Torque M5 terminal nut on regulator to 4.5 Nm/40 lb. in.
 - Connect R terminal to tachometer or relay. R terminal taps AC voltage, typically half the charge voltage. Torque M6 terminal nut on regulator to 4.5 Nm/40 lb. in.

Slip bushing must be tightened against bracket — see "CAUTION" above

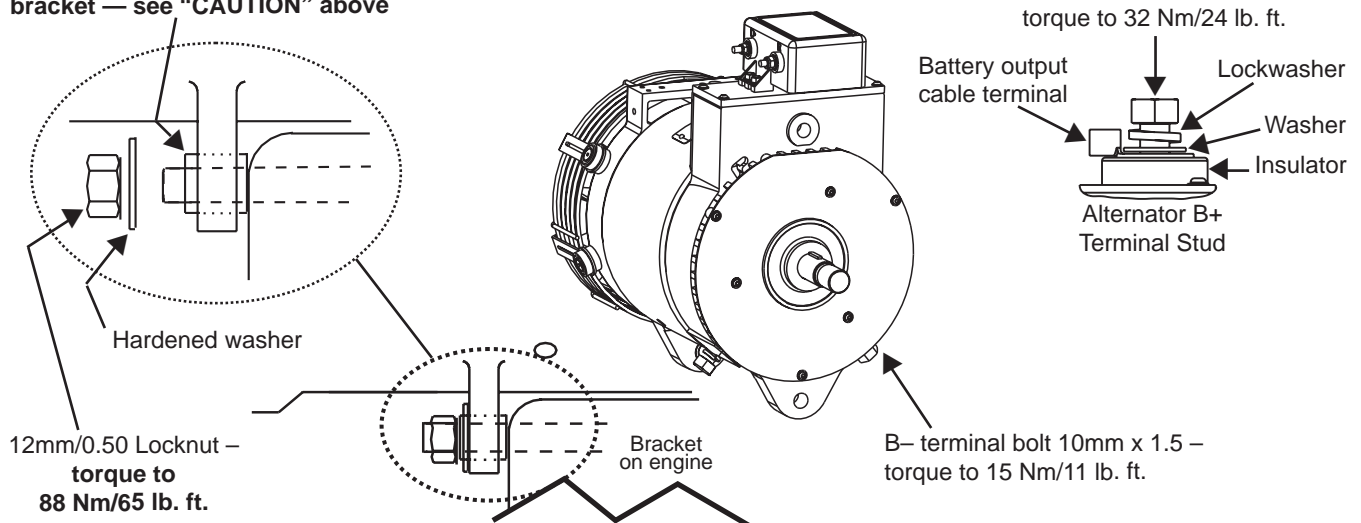

Figure 1 - C656 Alternator Installation Details