



Install alternator and regulator per diagrams
on pages 1 and 2.

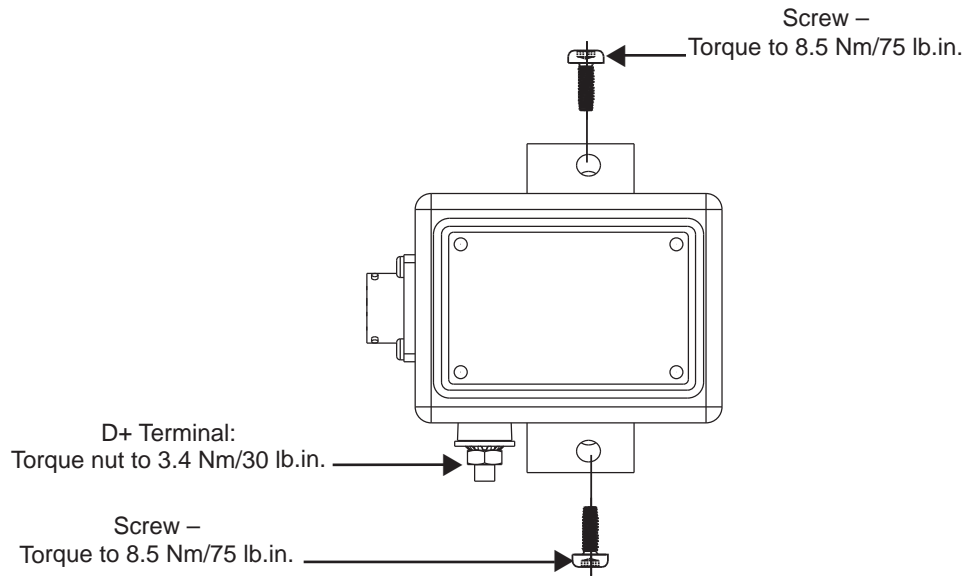

Figure 1a – N3043 Regulator Wiring Connections

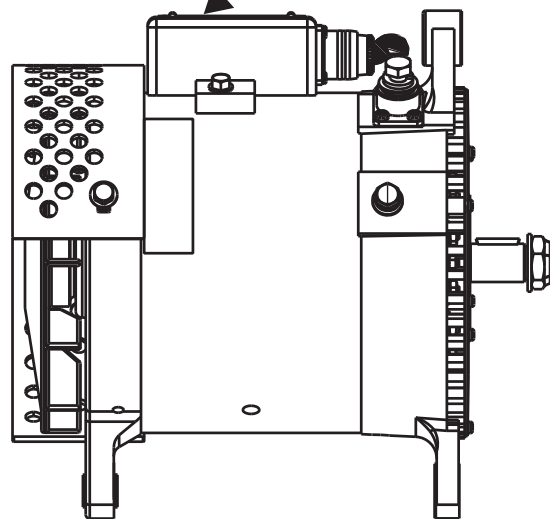

Figure 1– N1245-1 Alternator shown

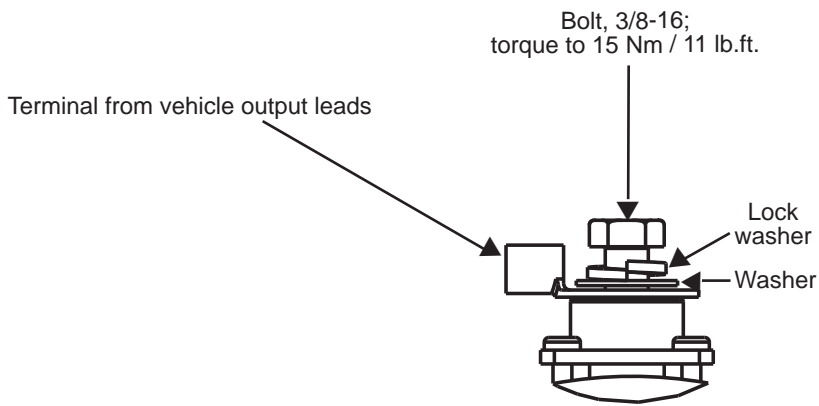

Figure 1b – 28 V B+ Terminal Stacking Order

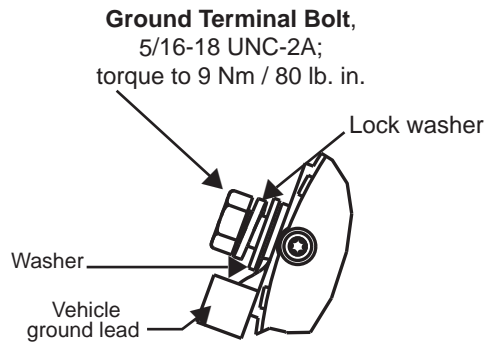
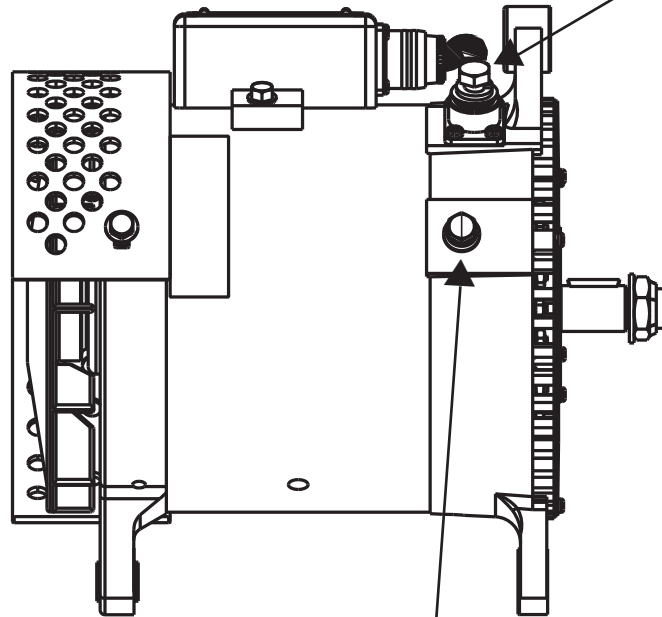

Figure 1c – Ground Terminal Stacking Order

If you have questions about your alternator or any of these instructions, or if you need to locate a Factory Authorized Service Dealer, please contact us at:
 C. E. Niehoff & Co. • 2021 Lee Street • Evanston, IL 60202 USA
 TEL: 800.643.4633 USA and Canada • TEL: 847.866.6030 outside USA and Canada • FAX: 847.492.1242
 E-mail us at service@CENiehoff.com