



Installation Instructions

WARNING

This symbol is used to indicate presence of hazards that can cause severe personal injury or substantial property damage.

CAUTION

This symbol is used to indicate presence of hazards that can cause minor property damage.

WARNING

The C717 alternator has maximum ambient operating temperature range of 65°C/149°F. Operating above this temperature range may cause irreparable damage to the alternator.

1. Install alternator:
 - a. Carefully place alternator on alternator mounting bracket.

CAUTION

Use caution when lifting alternator to prevent possible minor personal injury. Use hoist along with alternator lifting ring located on top of alternator.

- b. Secure alternator to alternator mounting bracket using four .5000-13 UNC-2A, grade 5 or higher mounting bolts with lock washers. Mounting bolts should extend 17.8/25.4 mm (0.7/1.0 in.) into alternator mounting rail. Torque mounting bolts to 88 Nm/65 lb. ft.
2. Units without pulley are shipped with shaft collar, disc spring washer, and nut. Customer should replace shaft collar pulley and secure with hardware furnished from factory. Torque hardware to 163 Nm/120 lb. ft. Some units are already shipped with pulley installed and torqued to proper value.

3. Install alternator drive belt and secure belt tension bracket assembly. Loop alternator drive belt over pulleys and align belt with polyvee grooves. Follow vehicle manufacturer's recommendations for belt tension.
4. All cabling, wiring or conduit must be supported within 305 mm/12 in. of termination on alternator.
5. Choose wire gauge capable of handling maximum alternator output with no more than 0.4 V drop on each leg from alternator to battery.
6. Regulator is furnished with OEM units and is supplied separately by request with aftermarket units. Mounting screws on regulator should be torqued to 8.5 Nm/75 lb. in.
7. Make electrical connections to CEN regulator as required, using proper ring terminals (follow vehicle manufacturer's diagram and separate instructions packed with extended wiring harness when used):
 - a. Make sure alternator-to-regulator harness is plugged securely in regulator receptacle.
 - b. A2-351 regulator furnished with some units has additional J1939 connector to vehicle. Securely attach additional vehicle cable to this connector as required.

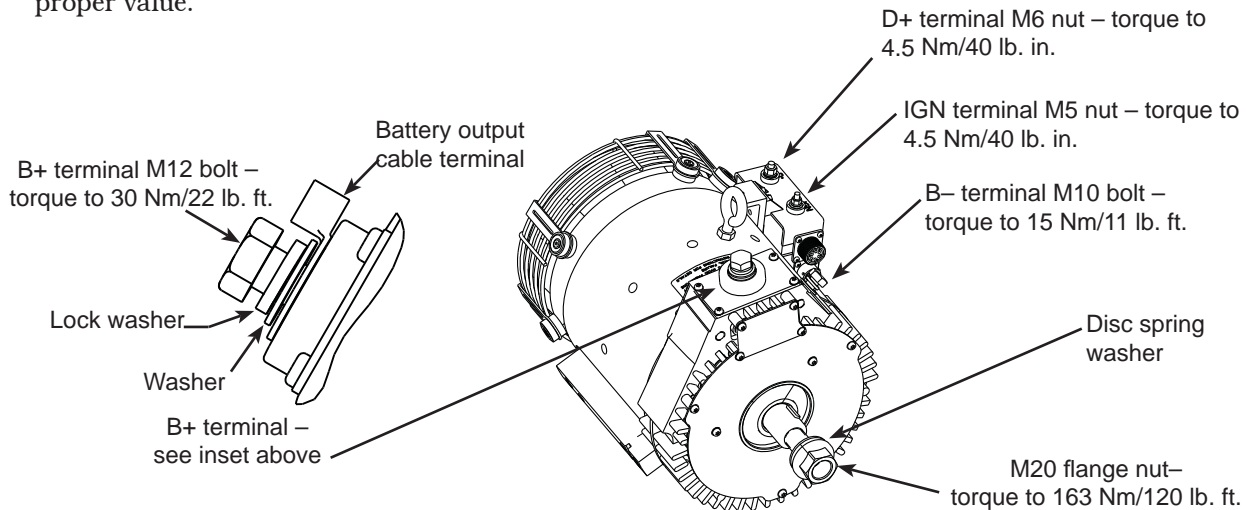

Figure 1 - C717-1 Alternator Installation Details