



Two changes have been made to the A5-543 DE rectifier-housing assembly:

The installation of the bearing only requires the beveled retaining ring.

- a. Use CEN A10–108 bearing tool placed on bearing outer race and press bearing into the DE bearing bore from the inside until it bottoms out on the ledge. See Figure 1.
- b. Install beveled retaining ring in groove. See Figure 1.
- c. Follow instructions in service manual to continue assembly.

A smaller outer-diameter pulley bushing (A9-984) and spiral ring (A9-572) are now required in place of the existing outer DE bushing and ring. Both the new bushing and spiral ring are enclosed in an envelope with the housing.

- a. Wind new spiral ring in groove around new ring carrier. Lubricate spiral ring with DuPont™ Krytox® GPL 225 or equivalent. Install ring carrier in bearing bore with short hub on carrier facing bearing. See Figure 1.

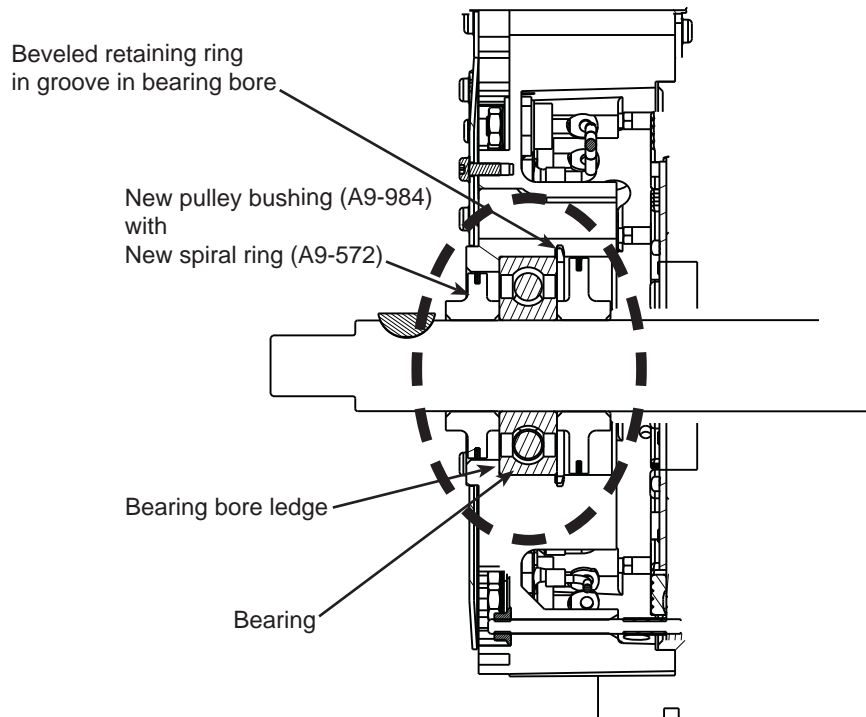

Figure 1—Replacement Details