



Follow these instructions to properly install an N1255 alternator fitted with an N3043 regulator:

1. Remove nut and disc spring washer from shaft, then remove and discard shaft collar.
2. Make sure Woodruff key is securely wedged in shaft slot.
3. Install pulley, disc spring washer, and lock nut on shaft in that order. See Figure 1. Torque pulley nut to 163 Nm/120 lb. ft.

CAUTION

Do not hammer pulley when installing pulley on shaft. Carefully slip-fit pulley over shaft to prevent shaft from moving out of place.

4. Mount alternator on engine and torque mounting feet to engine manufacturer's specifications.

CAUTION

Failure to tighten slip bushing in rear mounting foot against mounting bracket can result in broken mounting feet or broken bracket.

5. Install belt on pulley and tension belt to engine manufacturer's recommendation (typically 80-120 lbs).
6. Connect vehicle B+ cable to alternator B+ terminal as shown in Figure 1. Install hardware in stacking order shown in Figure 2. Torque B+ terminal hardware to 15 Nm/11 lb. in.
7. Connect vehicle B- cable to alternator B- terminal. See Figure 1. Install cable hardware in stacking order shown in Figure 3. Torque B- terminal bolts to 9 Nm/80 lb. in.

CAUTION

All cables must be supported within 300 mm (12 in.) to prevent twisting, loosening, and damage to terminals.

8. Install N3043 regulator according to instructions on page 2.

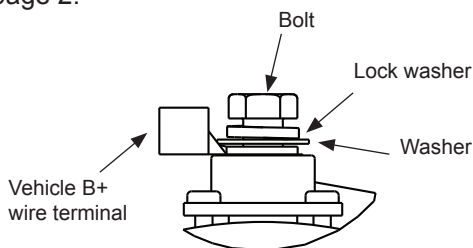

Figure 2: B+ Terminal Hardware Stacking Order

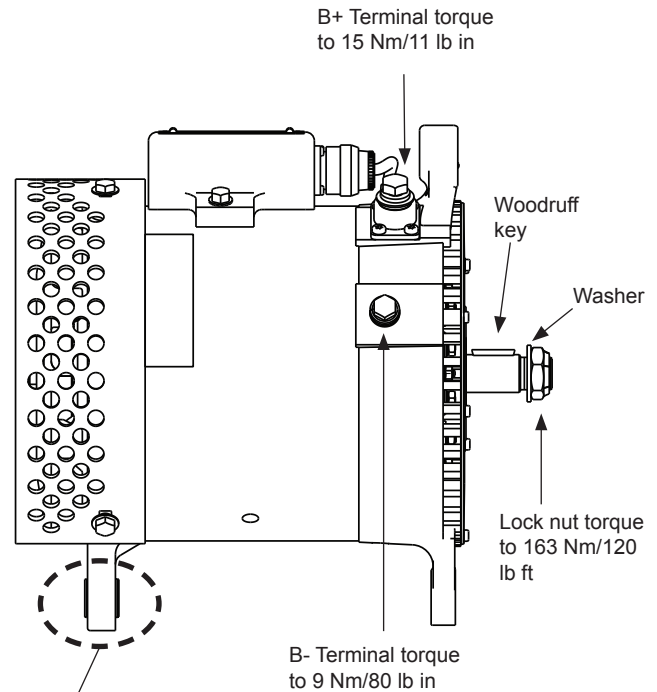

Figure 1: N1255 Alternator Installation

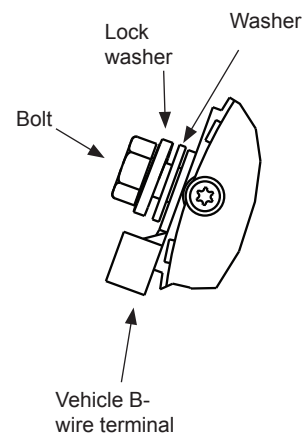
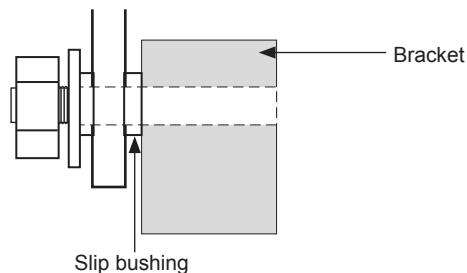

Figure 3: B- (Ground) Terminal Hardware Stacking Order

N3043 Regulator Installation

1. Align regulator tabs with screw holes on alternator shell and install mounting screws. Torque screws to 8.5 Nm/75 lb. in. See Figure 4.
2. Connect alternator-to-regulator harness to regulator.
3. Connect wire leads to D+ terminal. D+ terminal taps DC voltage (5A maximum). Torque hardware to 8.5 Nm/75 lb. in.

CAUTION

All cables must be supported within 300 mm (12 in.) to prevent twisting, loosening, and damage to terminals.

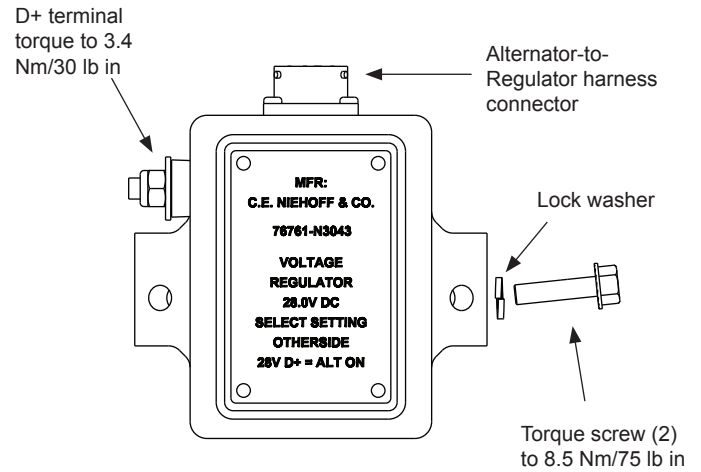

Figure 4: N3043 Regulator

If you have questions about your alternator or these instructions, or if you need to locate a Factory Authorized Service Dealer, please contact us at:
C. E. Niehoff & Co. • 2021 Lee Street • Evanston, IL 60202 USA
TEL: 800.643.4633 USA and Canada • TEL: 847.866.6030 outside USA and Canada • FAX: 847.492.1242
E-mail us at service@CENiehoff.com