



## C852 Alternator OEM Installation Instructions

CEN alternator model C852 is a cradle mount, isolated ground alternator rated at 28 volts/ 550 amps. To insure proper installation, follow instructions below.

1. Alternators shipped without pulley are shipped with shaft collar, disc spring washer, and nut installed. Remove and discard shaft collar. Make sure Woodruff key is level and securely wedged in slot in shaft.
2. Ensure fan is fully seated and spins freely. Then install pulley and furnished disc spring washer with beveled side facing pulley. Torque pulley nut to 163 Nm/120 lb. ft. See Figure 1.

**CAUTION** Do not hammer pulley when installing pulley on shaft. Carefully slip-fit pulley over shaft to prevent woodruff key from moving out of place.

3. Mount alternator on engine. Use hardened steel washers and 0.5-13 UNC-2B bolts, grade 5 bolts or higher. Torque mounting bolts to 88 Nm/65 lb. ft. or to engine manufacturer's specifications.

**CAUTION** Minimum recommended thread engagement is 12.7 mm (0.5") into alternator drive end mounting holes and 16.5 mm (0.65") into anti-drive end mounting holes. Maximum mounting screw depth into alternator regardless of washer and bracket stackup is 18.3 mm (0.72 in.) into drive end mounting holes and 24.1 mm (0.95 in.) into anti-drive end mounting holes.

(0.95 in.) into anti-drive end mounting holes. See Figure 1 inset. **EXCEEDING MAXIMUM DEPTH WILL RESULT IN IMMEDIATE ALTERNATOR FAILURE.**

4. Install vibration damper bracket on alternator per engine or vehicle manufacturer's instructions if included with alternator and/or required by engine manufacturer.
5. Install cable support bracket(s) on alternator per engine or vehicle manufacturer's instructions if included with alternator and/or required by engine manufacturer.
6. Install drive belt per engine manufacturer's instructions. Typical belt tension is between 80-120 lbs nominal.
7. Connect vehicle B+ cable to alternator B+ terminal (see Figure 2 for terminal location). Install hardware on B+ terminal in stacking order shown in Figure 3. Torque to 30 Nm/22 lb. ft.
8. Connect vehicle B- cable to alternator B- terminal (see Figure 2 for terminal location). Install hardware on B- terminal in stacking order shown in Figure 3. Torque to 30 Nm/22 lb. ft.

**NOTICE** Wire gauge must be capable of handling maximum alternator output with minimum voltage drop. All cables must be supported within 300 mm (12 in.) to prevent twisting, loosening, and damage to terminals.

9. Install regulator according to instructions on page 2.

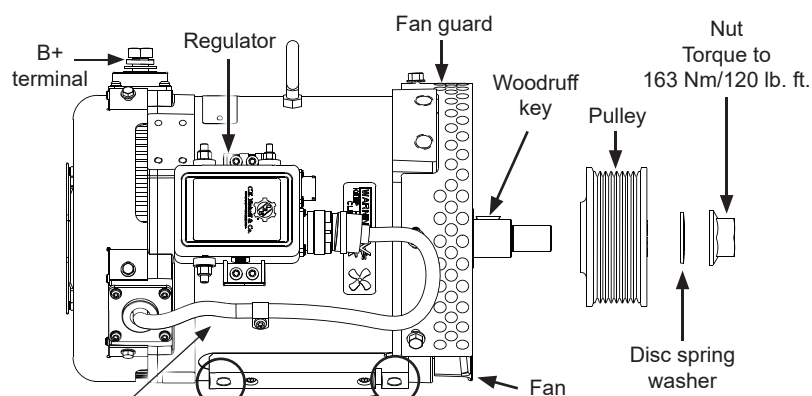

**Figure 1: C852 Alternator Installation Connections (side view)**

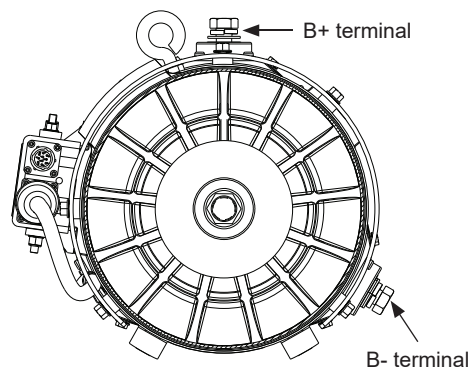
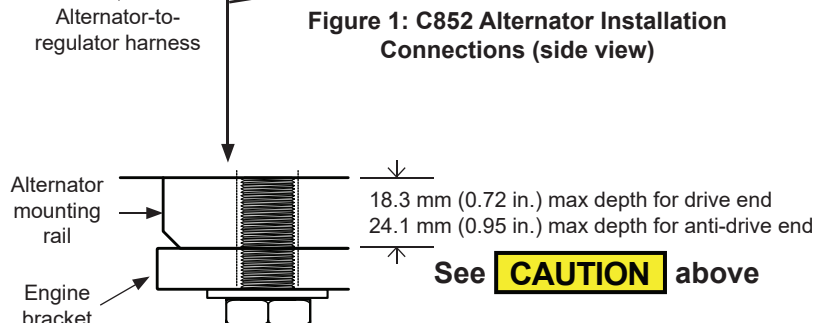

**Figure 2: C852 Alternator Installation Connections (drive-end view)**

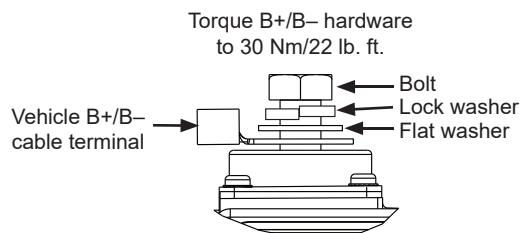

**Figure 3: B+/B- Terminal Hardware Stacking Order**

## CEN Regulator Installation

1. Regulator has four selectable set points. Before installing regulator, verify appropriate switch setting for your application and change if necessary. See Figure 4 and Table 1 for fixed voltage set point options when used without battery sensor/harness. See Table 2 for battery chemistry-based charge profiles when used with compatible CEN battery sensor/harness. **Contact battery manufacturer or vehicle OEM for charging set point recommendations for your environment or application if necessary.**
2. Mount regulator on alternator shell with included screws, lock washers, and insulator bracket (see Figure 5) or remotely<sup>1</sup> as required by application. Torque mounting screws to 8.5 Nm/75 lb. in.
3. Plug alternator-to-regulator harness into receptacle on regulator. See Figure 6 for receptacle location.
4. Connect regulator terminals as required by vehicle:
  - Regulator **IGN terminal** (required) must receive voltage from vehicle DC ignition source or multiplex system in order to energize charging system. Torque to 4.5 Nm/40 lb. in. See Figure 6.

**NOTICE** Voltage should be present at regulator IGN terminal when ignition is on or engine is running. No voltage should be present when ignition is off or engine is not running.

- Regulator **D+ terminal** (if required by vehicle) provides DC system battery voltage to vehicle (5A maximum) for charge indicator lamp, relay, or multiplex while alternator is producing output. Torque terminal hardware to 4.5 Nm/40 lb. in. See Figure 6.
- Regulator **P/AC/R terminal** (if required by vehicle) taps AC voltage from alternator, typically half the charge voltage (5A maximum). P/AC terminal provides alternator RPM frequency at 10:1 ratio for use with tachometer. Torque terminal hardware to 4.5 Nm/40 lb. in. See Figure 6.

**NOTICE** If using relay for P/AC/R circuit, coil must be diode-protected and properly rated.

5. If using a J1939/temperature-voltage sense harness, plug J1939 harness into J1939 receptacle on regulator. See Figure 6 for receptacle location. Refer to installation instructions included with harness for more information. Harness sold separately<sup>2</sup>.



Figure 4: Regulator Voltage Selection Switch (on underside of regulator)

Switch Position	Conventional Regulator Set Point or Smart Series with <b><i>no Sensor/Harness Connected</i></b>
1	27.5 V
2	28.0 V
3	28.5 V
4	29.0 V

Switch Position	Battery profile for Smart Series Regulators with <b><i>Sensor/Harness Connected</i></b> <sup>2</sup>
1	Maintenance (D category)
2	Maintenance-free (Group 31)
3	AGM
4	29.0 fixed

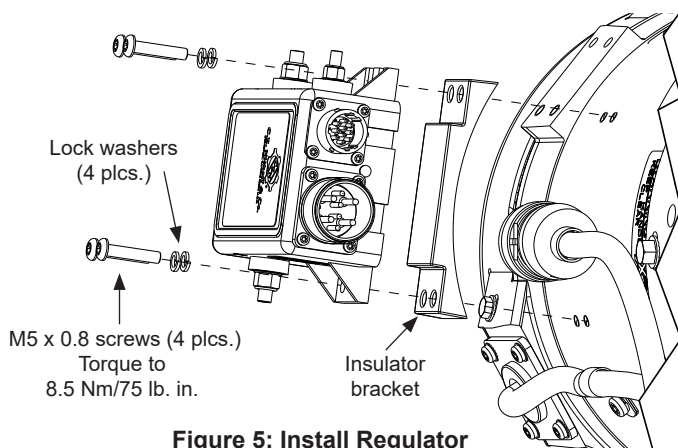

Figure 5: Install Regulator

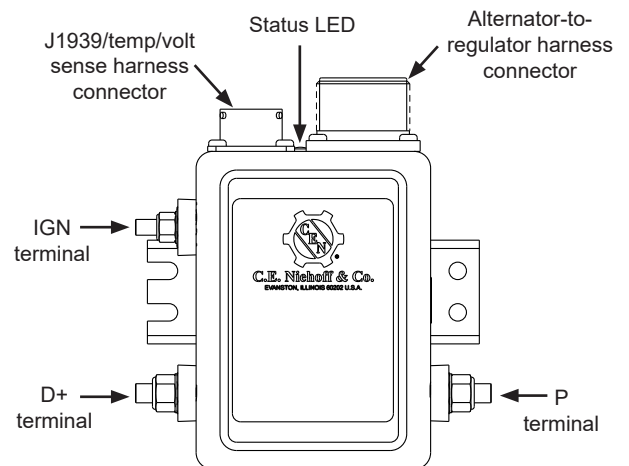

Figure 6: Smart Series Regulator Connections

1. Contact CEN for regulator extension harness options.
2. Contact CEN for alternative sensor/harness options

If you have questions about your alternator or these instructions, or if you need to locate a Factory Authorized Service Distributor, please contact us at:  
 C. E. Niehoff & Co. • 2021 Lee Street • Evanston, IL 60202 USA  
 TEL: 800.643.4633 USA and Canada • TEL: 847.866.6030 outside USA and Canada • FAX: 847.492.1242  
 E-mail us at [service@CENiehoff.com](mailto:service@CENiehoff.com)