



**CAUTION**

This symbol is used to indicate presence of hazards that can cause minor property damage.

Install alternator as shown in Figure 1:

**CAUTION**

Slip bushing located in rear mounting foot must be securely tightened against alternator mounting bracket on engine. Failure to do so can result in broken mounting feet or broken upper mounting bracket.

1. Units are shipped with pulley, belleville washer, and nut. Check torque on locknut for 163 Nm/ 120 lb. ft.
2. Use hardened washers between aluminum surfaces and bolt heads and nuts. Torque mounting bolts to 88 Nm/65 lb. ft.
3. All cabling, wiring or conduit must be supported within 305 mm/12 in. of termination on alternator.
4. Choose wire gauge for B+ and B- cables capable of handling maximum alternator output with minimum voltage drop.

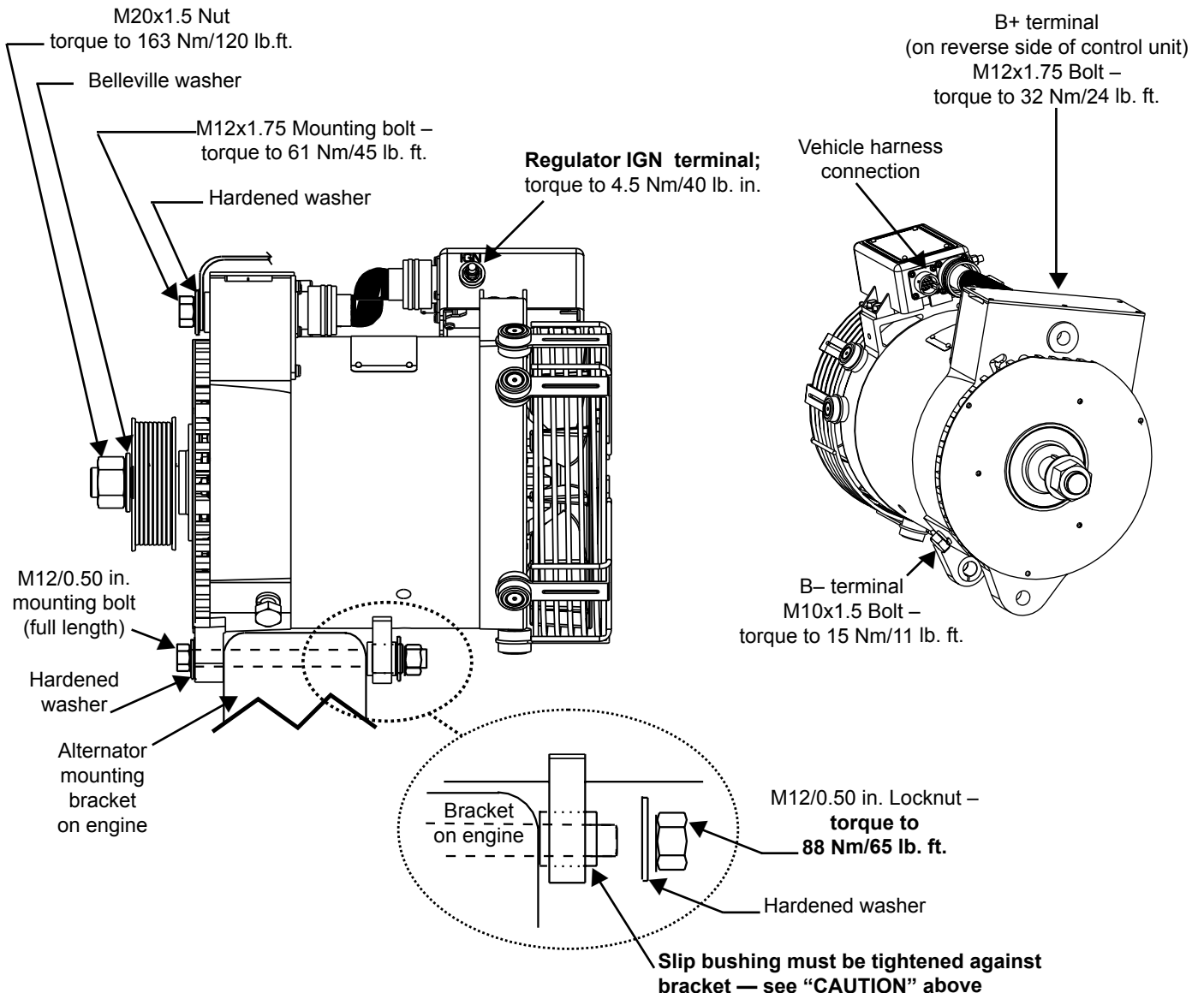

Figure 1 - Alternator Installation Details