



Issue Date: June 15, 2004

SB Number: SB0017B

Service Tip: Cleaning the C701 and C703 Alternators

Airways must be free of debris so air flow through alternator is unobstructed. Alternator works at optimum efficiency when sufficient air flow through passages cools internal components.

DO NOT USE WATER OR CHEMICALS TO CLEAN THE ALTERNATOR.

To clean alternator at scheduled intervals, use compressed air to blow out debris in fan, fan guard, and all airways at drive end and anti-drive end.

After cleaning, thoroughly inspect drive end airways for remaining debris. You may need to remove the drive end cover plate. If any debris remains in the drive end airways, use a **small, soft-bristled brush**, like a soft-bristled toothbrush to gently remove residual dirt and lint.

Make sure drive end cover plate is re-installed and screws are torqued to 2.3 Nm/20 lb. in.

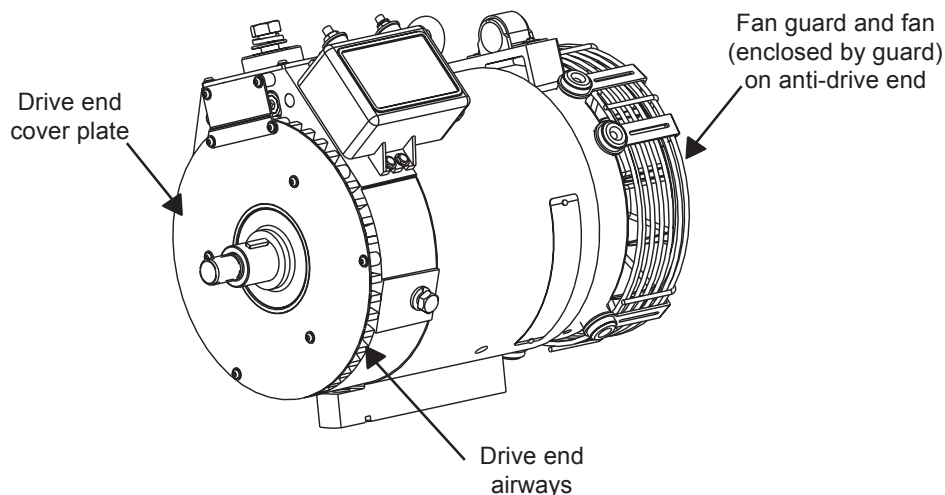

Please file this CEN Service Bulletin with your CEN Literature.

Please forward a copy of this information to the appropriate people in your company.