



CAUTION

This symbol is used to indicate presence of hazards that can cause minor property damage.

Install N1126-2 alternator as shown in Figure 1:

CAUTION

Slip bushing located in rear mounting foot must be securely tightened against alternator mounting bracket on engine. Failure to do so can result in broken mounting feet or broken upper mounting bracket.

1. Units are shipped with shaft collar, hardened washer and locknut. Remove and discard shaft collar. Install pulley and furnished hardened washer. Torque locknut to 136 Nm/ 100 lb. ft.
2. Use hardened washers between aluminum surfaces and bolt heads and nuts. Torque mounting bolts to 80 Nm/60 lb. ft.
3. All cabling, wiring or conduit must be supported within 305 mm/12 in. of termination on alternator.
4. Choose wire gauge for B+ and B- cables capable of handling maximum alternator output with minimum voltage drop.

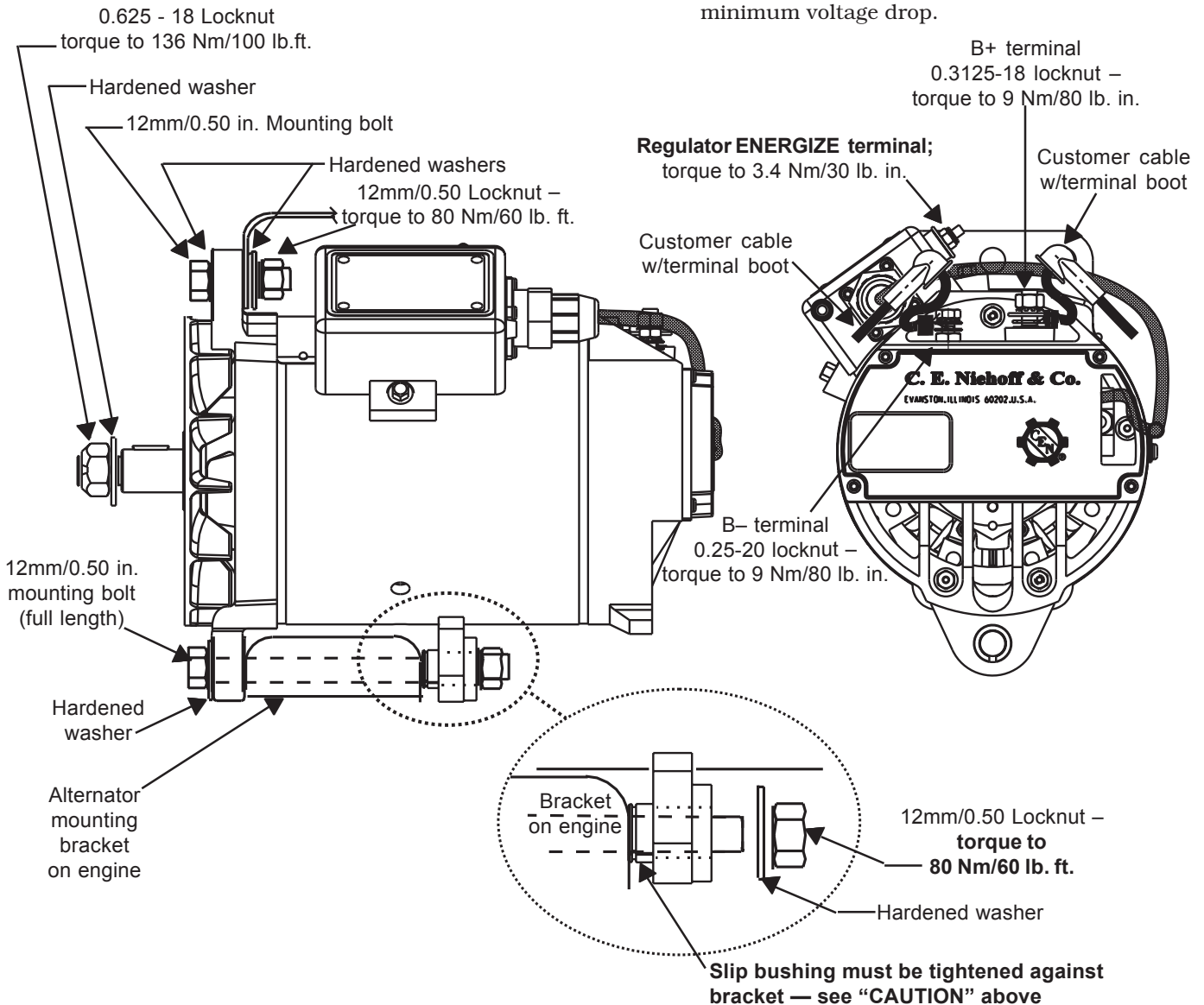

Figure 1 - N1126-2 Alternator Installation Details