



**CAUTION**

This symbol is used to indicate presence of hazard(s) that can cause minor property damage.

Install alternator as shown in Figure 1:

**CAUTION**

Slip bushing located in rear mounting foot must be securely tightened against alternator mounting bracket on engine. Failure to do so can result in broken mounting feet or broken upper mounting bracket.

1. Units are shipped with shaft collar, Belleville washer, and nut. Remove shaft collar. Install pulley specified by customer, washer, and nut. Torque nut to 163 Nm/ 120 lb. ft.
2. Use hardened washers between aluminum surfaces and bolt heads and nuts. Torque mounting bolts as shown in Figure 1.
3. All cabling, wiring or conduit must be supported within 305 mm/12 in. of termination on alternator.
4. Choose wire gauge for B+ and B- cables capable of handling maximum alternator output with minimum voltage drop. See Figures 1 and 2 for proper B+ and B- connections.
5. Install regulator as specified by customer.
6. Install battery isolator as specified by customer.

**B+ connections on alternator**

Bolt, 0.3750-16 UNC-2A x 1.00; torque to 20 Nm / 15 lb.ft. when securing B+ cables. Both positive cables must be connected together at battery positive potential when alternator is installed in vehicle and during operation. Interconnect cable is part of vehicle cabling.

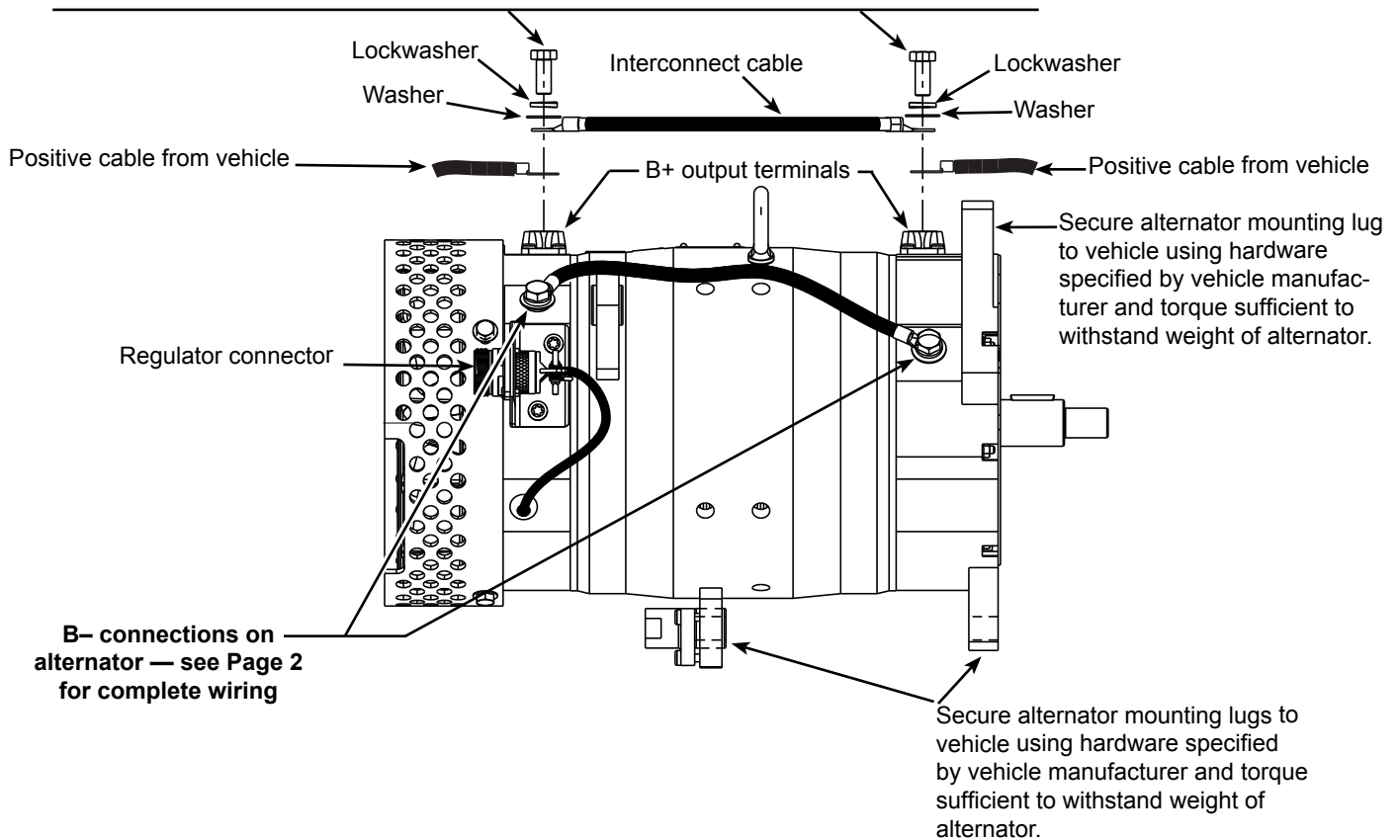
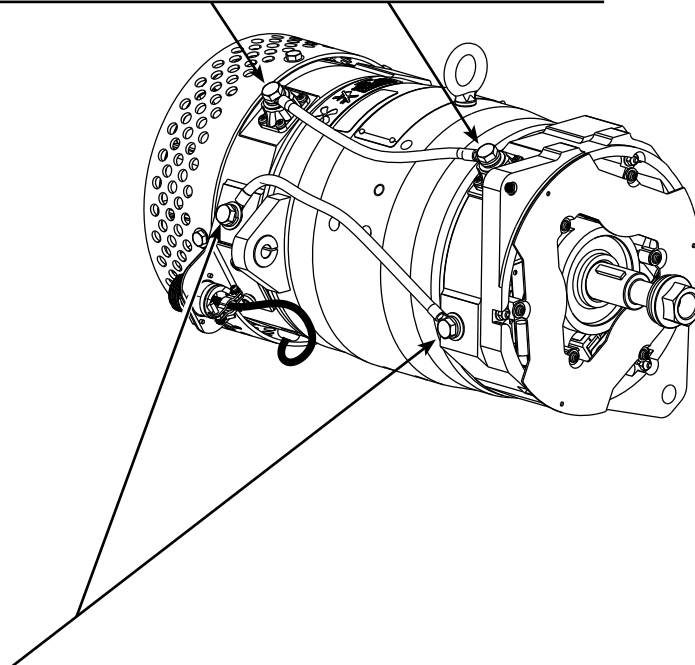

Figure 1 - Alternator Installation Details (see page 2 for B- Details)

**B+ connections on alternator — see Page 1 for complete wiring**



**B- connections on alternator**

Bolt, 0.3750-16 UNC-2A x 0.875; torque to 20 Nm / 15 lb.ft. when securing B- cables.

Both ground cables must be connected to vehicle's common ground.

An interconnect cable is required as shown if a single cable to vehicle common ground is used.

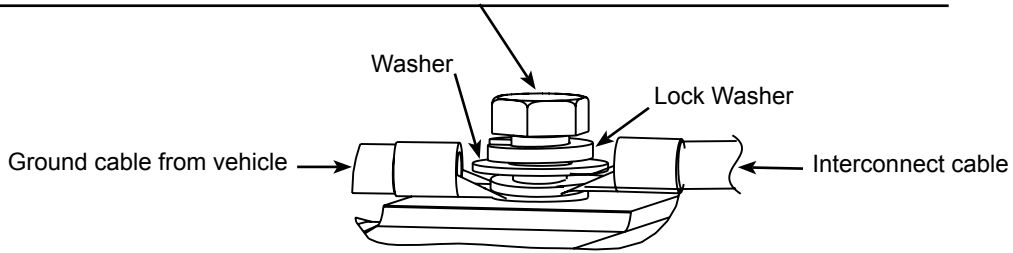

Figure 2 - Alternator B- Installation Details

If you have questions about your alternator or any of these instructions, or if you need to locate a Factory Authorized Service Dealer, please contact us at:

C. E. Niehoff & Co. • 2021 Lee Street • Evanston, IL 60202 USA

TEL: 800.643.4633 USA and Canada • TEL: 847.866.6030 outside USA and Canada • FAX: 847.492.1242

E-mail us at [service@CENiehoff.com](mailto:service@CENiehoff.com)