



Hazard Definitions

These terms are used to bring attention to presence of hazard(s) of various risk levels or to important information concerning product life.

CAUTION

Indicates presence of hazards that will or can cause minor personal injury or property damage.

NOTICE

Indicates special instructions on installation, operation or maintenance that are important but not related to personal injury hazards.

Table of Contents

Section A: Wiring Diagram 2
 Section B: Basic Troubleshooting 3
 Section C: Advanced Troubleshooting 4

Battery Conditions

NOTICE

Until temperatures of electrical system components stabilize, these conditions may be observed during cold start voltage tests.

- **Maintenance/Low Maintenance Battery:**
 - Immediately after engine starts, system volts are lower than regulator setpoint, and amps are medium.
 - 3-5 minutes into charge cycle, system volts increase and amps decrease.
 - 5-10 minutes into charge cycle, system volts increase to, or near, regulator setpoint, and amps decrease to a minimum.
 - Low maintenance battery has same characteristics with slightly longer recharge times.
- **Maintenance-free Battery:**
 - Immediately after engine starts, system volts are lower than regulator setpoint with low charging amps.
 - Once the charge cycle begins, low volts and low amps are still present.
 - After the alternator energizes, volts will increase several tenths. Amps will increase gradually, then quickly to medium to high amps.
 - Finally, volts increase to setpoint and amps will decrease.

The time it takes to reach optimum voltage and amperage will vary with engine speed, load, and ambient temperature.
- **High-cycle Maintenance-free Battery:**
 - These batteries respond better than standard maintenance-free. Charge acceptance of these batteries may display characteristics similar to maintenance batteries.

Charge Volt and Amp Values

Voltage and amperage levels are functions of the battery state of charge. If batteries are in a state of discharge, as after extended cranking time to start the engine, system volts when measured after the engine is started will be lower than the regulator setpoint, and system

amps will be high. This condition is normal for the charging system. Measured values of system volts and amps will depend on the level of battery discharge; in other words, the greater the battery discharge level, the lower the system volts and higher the system amps will be.

Voltage and amperage readings will change: System voltage reading will increase to regulator setpoint, and system amps will decrease to low level (depending on other loads) as batteries recover and become fully charged.

- **Low Amps:** Minimum or lowest charging system amp value required to maintain battery state of charge; obtained when testing the charging system with a fully charged battery and no other loads applied. This value will vary with battery type.
- **Medium Amps:** System amp value that can cause battery temperature to rise above adequate charging temperature within 4-8 hours of charge time. To prevent battery damage, charge amps should be decreased when battery temperature rises. Check battery manufacturer recommendations on proper rates of charge amps.
- **High Amps:** System amp value that can cause battery temperature to rise above adequate charging temperature within 2-3 hours. To prevent battery damage, charge amps should be decreased when the battery temperature rises. Check battery manufacturer recommendations on proper rates of charge amps.
- **Battery Voltage:** Steady-state volt value measured with battery in open circuit with no battery load. This value relates to battery state of charge.
- **Charge Voltage:** Volt value obtained when charging system is operating. This value will be higher than battery voltage and must never exceed the regulator voltage setpoint.
- **B+ Voltage:** Volt value obtained when measuring voltage at battery positive terminal or alternator B+ terminal.
- **Surface Charge:** Higher-than-normal battery voltage occurring when battery is removed from battery charger. Surface charge must be removed to determine true battery voltage and state of charge.
- **Significant Magnetism:** Change in strength or intensity of a magnetic field present in the alternator rotor shaft when the field coil is energized. The magnetic field strength when the field coil is energized should feel stronger than when the field is not energized.
- **Voltage Droop or Sag:** Normal condition which occurs when the load demand on an alternator is greater than rated alternator output at given rotor shaft RPM.

**CEN NI326-I Alternator
Description and Operation**

N1326-1 28 V (300 A) alternator is self-rectifying. All windings and current-transmitting components are non-moving, so there are no brushes or slip rings to wear out. Load-dump protection limits peak voltage to less than 55 volts during maximum load change over speed range in batteryless operation.

Ignition switch energizes regulator, and then field coil is energized.

N3007 regulator furnished with this unit is flat temperature compensated at 27.7 ± 0.3 V at 72 F.

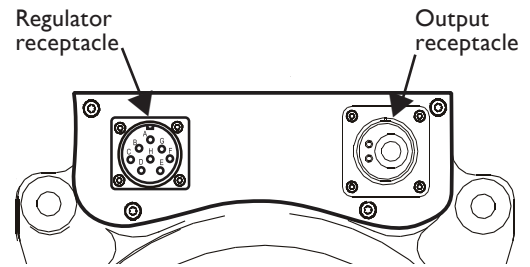
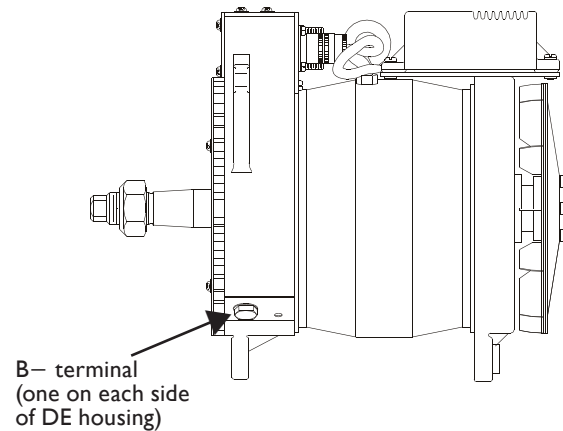

Figure 1 — NI326-I Control Assembly



**Figure 2 — NI326-I Alternator Terminals
(N3007 Regulator Attached to Alternator)**

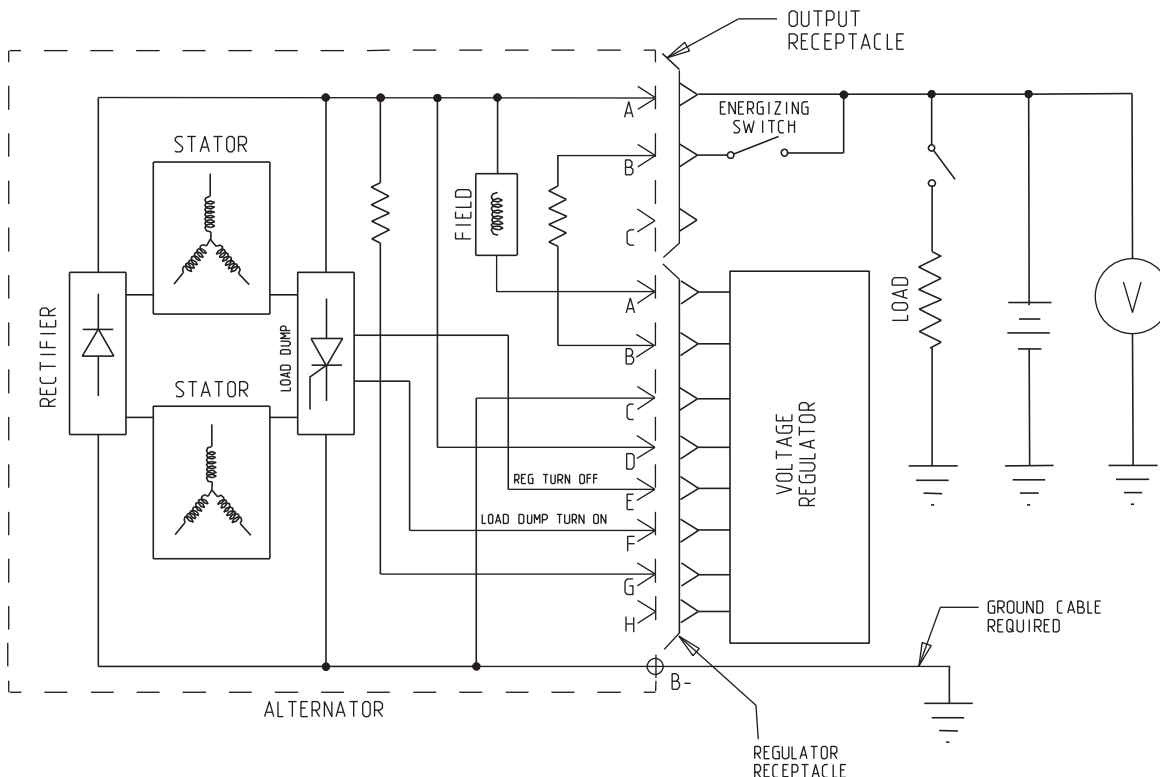

Figure 3 — NI326-I Alternator with N3007 Regulator Wiring Diagram



Tools and Equipment for Job

- Digital Multimeter (DMM)
- Ammeter (digital, inductive)
- Jumper wires

Identification Record

List the following for proper troubleshooting:

- Alternator model number _____
- Regulator model number _____
- Setpoints listed on regulator _____

Preliminary Check-out

Check symptoms in Table 1 and correct if necessary.

TABLE 1—System Conditions	
SYMPTOM	ACTION
Low Voltage Output	Check: loose drive belt; low battery state of charge. Check: current load on system is greater than alternator can produce. Check: defective wiring or poor ground path; low regulator setpoint. Check: defective alternator and/or regulator.
High Voltage Output	Check: wrong regulator. Check: high regulator setpoint. Check: defective regulator.
No Voltage Output	Check: alternator. Check: broken drive belt. Check: battery voltage at alternator output terminal. Check: defective alternator and/or regulator.

Basic Troubleshooting

- Inspect charging system components for damage**
Check connections at regulator and vehicle harnesses. Repair or replace any damaged component before troubleshooting.
- Inspect all vehicle battery connections**
Connections must be clean and tight.
- Determine battery voltages and states of charge**
If batteries are discharged, recharge or replace batteries as necessary. Electrical system cannot be properly tested unless batteries are charged 95% or higher.
- Operate vehicle**
Observe charge voltage.

CAUTION

 If charge voltage is above 33 volts, immediately shut down system. Electrical system damage may occur if charging system is allowed to operate at high voltage. Go to Table 1 at left.
 If voltage is at or below regulator setpoint, let charging system operate for several minutes to normalize operating temperature.
- Observe charge volts and amps**
Charge voltage should increase and charge amps should decrease. If charge voltage does not increase within ten minutes, continue to next step.
- Batteries** are considered fully charged if charge voltage is at regulator setpoint and charge amps remain at lowest value for 10 minutes.
- If charging system** is not performing properly, go to Chart 1, page 4.

Chart 1 – No Output

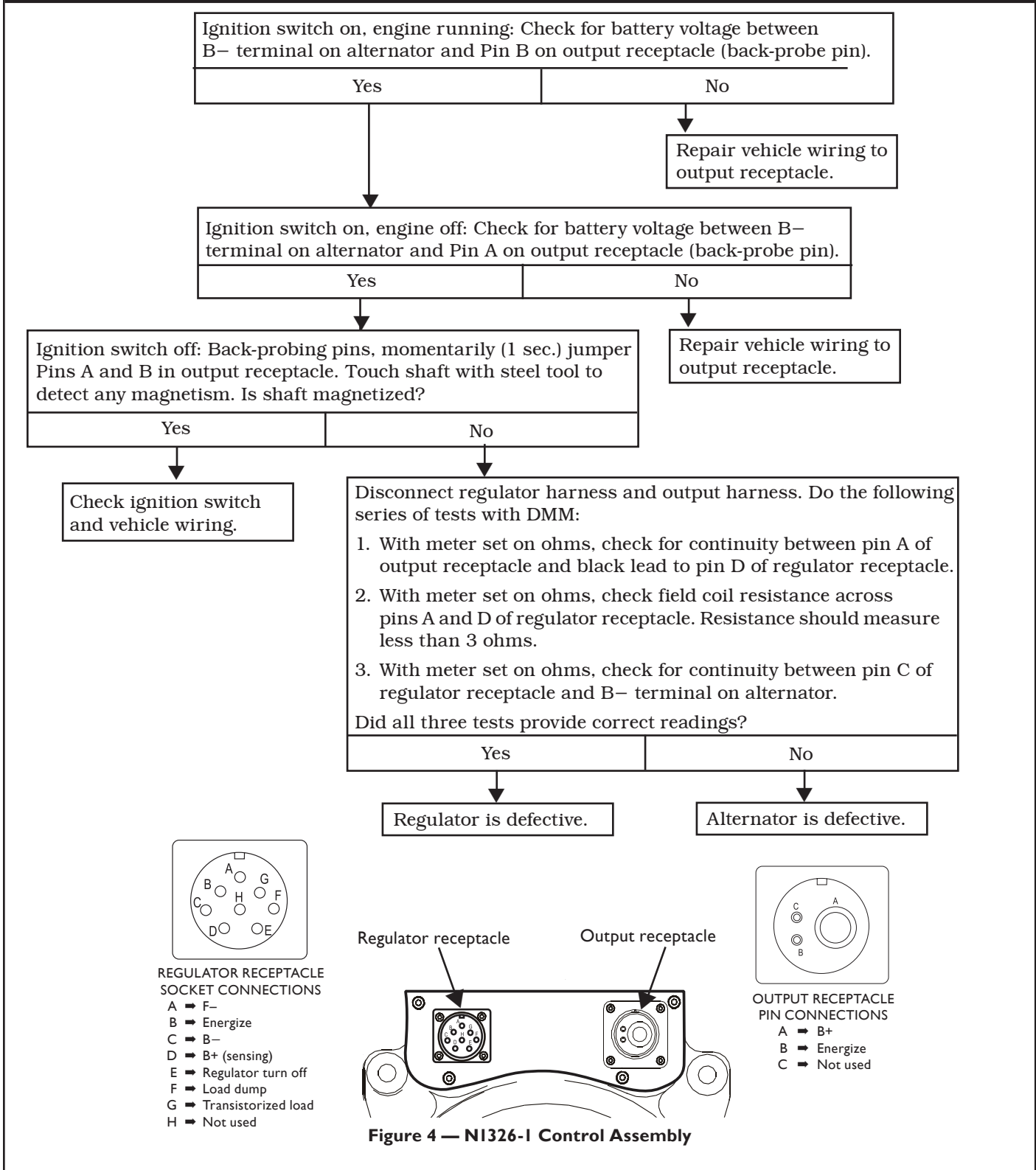

If you have questions about your alternator or any of these test procedures, or if you need to locate a Factory Authorized Service Dealer, please contact us at:

C. E. Niehoff & Co. • 2021 Lee Street • Evanston, IL 60202 USA

TEL: (800) 643-4633 USA and Canada • TEL: (847) 866-6030 outside USA and Canada • FAX: (847) 492-1242

E-mail us at service@CENiehoff.com