



**C625 Alternator Installation**

CEN model C625 is a hinge mount, negative ground alternator rated at 28V/260A. Follow these instructions to ensure proper installation.

1. Alternators not shipped with pulley are shipped with shaft collar, disc spring washer, and nut installed. Remove and discard shaft collar. Make sure Woodruff key is securely wedged in slot in shaft.
2. Install pulley and furnished disc spring washer with beveled side facing pulley. Torque pulley nut to 163 Nm/120 lb. ft. See Figure 1.

**CAUTION** Do not hammer pulley when installing pulley on shaft. Carefully slip-fit pulley over shaft to prevent woodruff key from moving out of place.

3. Install alternator on mounting bracket according to vehicle manufacturer's specifications. Use hardened flat washers between mounting surfaces and bolt heads or lockwashers. Mounting bolts should be Grade 5 (Metric Grade 8.8), minimum.

4. Tension belt to vehicle manufacturer's specifications.
5. Connect vehicle B+ cable to alternator B+ terminal. Install hardware on B+ terminal in stacking order shown in Figure 2. Torque to 32 Nm/24 lb. ft.
6. Connect vehicle B- cable to alternator B- terminal. Install B- hardware in stacking order shown in Figure 3. Torque to 15 Nm/11 lb. in.

**NOTICE** Wire gauge must be capable of handling maximum alternator output with minimum voltage drop. All cables must be supported within 300 mm (12 in.) to prevent twisting, loosening, and damage to terminals.

7. Connect alternator-to-regulator harness to regulator as shown in Figure 1.
8. If regulator was supplied separately, install regulator according to instructions on page 2.

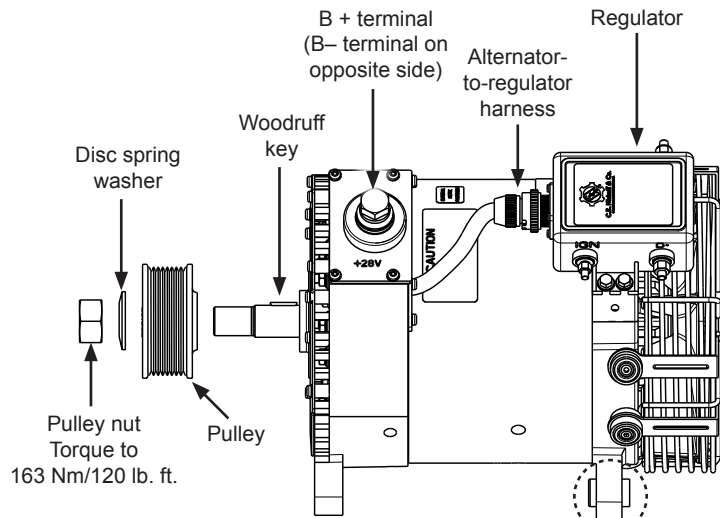

**CAUTION** Slip bushing in rear mounting foot must be tightened against mounting bracket to prevent damage to mounting feet and bracket.

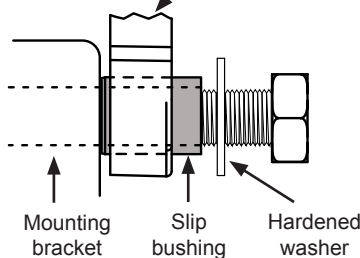

Figure 1: C625 Alternator Connections

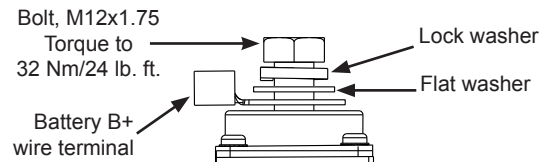

Figure 2: B+ Terminal Hardware Stacking Order

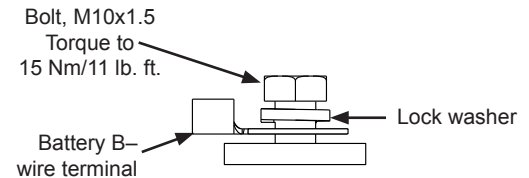

Figure 3: B- Terminal Hardware Stacking Order

# Regulator Installation

1. Turn regulator over and make sure set point of switch at bottom of regulator is appropriate for type of battery used in vehicle . If necessary, change switch set point. See Figure 4 and Table 1 for voltage set point options.
2. Mount regulator on alternator or remotely\* if applicable. Torque mounting screws to 8.5 Nm/75 lb. in.
3. Securely plug alternator-to-regulator harness into receptacle on regulator. See Figure 5 for receptacle location.
4. Connect regulator terminals as required by vehicle:
  - **IGN terminal** (required) must receive voltage from vehicle switched DC ignition source or multiplex in order to energize regulator. Torque to 4.5 Nm/40 lb. in. See Figure 5.

**NOTICE** Voltage should be present at IGN terminal when ignition is on or engine is running. No voltage should be present when ignition is off or engine is not running.

- **D+ terminal** (if required) provides DC system battery voltage to vehicle (5A maximum) for charge indicator lamp, relay, or multiplex while alternator is producing output. Torque terminal hardware to 4.5 Nm/40 lb. in. See Figure 5.
- **P/AC terminal** (if required) taps AC voltage from alternator, typically half the charge voltage (3A maximum). P/AC terminal provides alternator RPM frequency at 10:1 ratio for use with tachometer. Torque terminal hardware to 4.5 Nm/40 lb. in. See Figure 5.

**NOTICE** If using relay for R/P/AC circuit, coil must be diode-protected and properly rated.

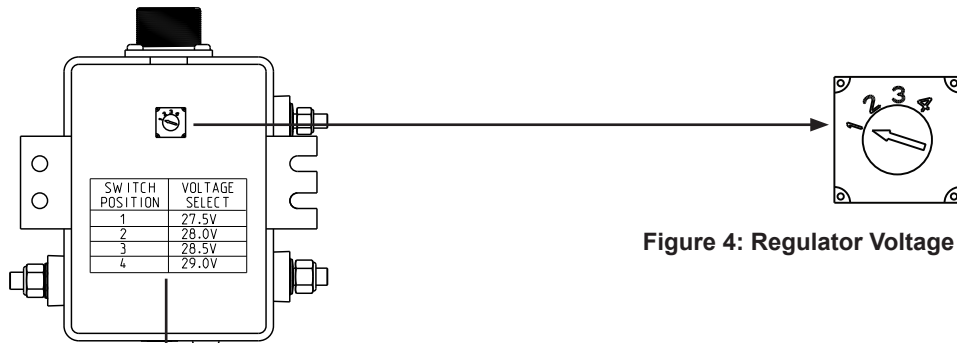

Figure 4: Regulator Voltage Selection Switch

Table 1: Regulator Switch Settings	
Position	Remote Sensing Not Connected
1	27.5 V
2	28.0 V
3	28.5 V
4	29.0 V

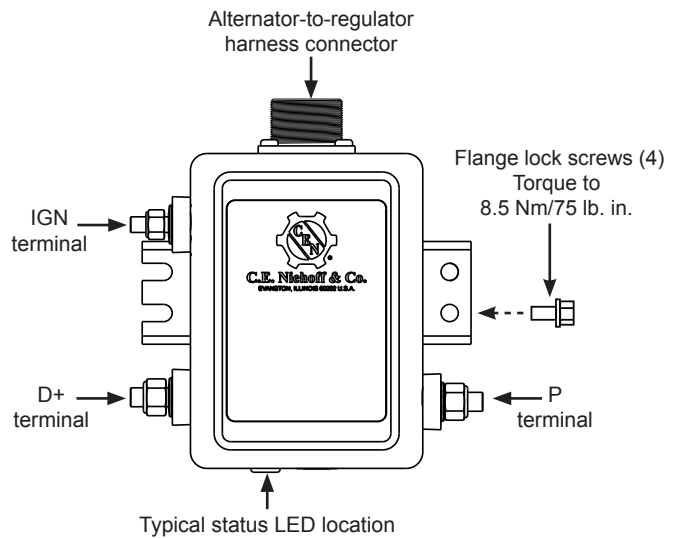

Figure 5: Typical Regulator Connections

\*Contact CEN for regulator extension harness options.

If you have questions about your alternator or any of these instructions, or if you need to locate a Factory authorized Service Distributor, please contact us at:  
 C. E. Niehoff & Co. • 2021 Lee Street • Evanston, IL 60202 USA  
 TEL: 800.643.4633 USA and Canada • TEL: 847.866.6030 outside USA and Canada • FAX: 847.492.1242  
 E-mail us at service@CENiehoff.com