



C2005(A,B,C,D) Smart Battery Sensor (SBS)

The CEN C2005 Smart Battery Sensor (SBS) monitors charging and discharging current, voltage, and temperature of batteries of all types and chemistries in 14V and/or 28V systems. This data is broadcast via J1939 across the vehicle network for use with telematics systems and advanced battery charging profiles. Compatible CEN Smart regulators will use this data to optimize charging profiles for all battery types under all environmental conditions. A, B, C, and D suffixes indicate different source addresses.

Installation

NOTICE See page 2 for alternate installation options and multiple-string battery bank installations.

1. Turn off vehicle battery switch and disconnect main vehicle ground cable from battery.
2. Connect C2005A battery-side terminal to battery negative post. If required, use optional mounting hardware kit (CEN P/N A9-2023, available separately) for flexible mounting options. Torque C2005A attaching hardware to 22.5 Nm/200 lb. in. and torque battery post hardware to battery manufacturer's specification. See Figures 1 and 2.
3. Connect vehicle B- cable to other side of C2005A. Torque attaching hardware to 22.5 Nm/200 lb. in.
4. Plug 4 socket connector of harness (CEN P/N A9-4079, available separately) into C2005A connector.
5. Plug 3 socket Deutsch connector of harness into vehicle J1939 backbone. J1939 extension harness and tee connectors may be necessary to extend harness length. Use terminating resistor if required by vehicle network (connector tees, extension harnesses, and terminating resistors available separately through commercial component distributors).
6. Attach wires from A9-4079 harness to batteries as follows:
 - 12V systems (Figure 1):
 - a. Attach white wire to +12V positive battery post. Stack hardware on top of existing battery cable terminals and torque to battery manufacturer's specification.
 - b. Cut and tape off red wire from A9-4079 harness.
 - 24V systems (Figure 2):
 - a. Attach white wire to +12V positive battery post. Stack hardware on top of existing battery cable terminals and torque to battery manufacturer's specification. If +12V sensing is unavailable or not required, cut and tape off white wire from A9-4079 harness.
 - b. Attach red wire to +24V positive battery post. Stack hardware on top of existing battery cable terminals and torque to battery manufacturer's specification.

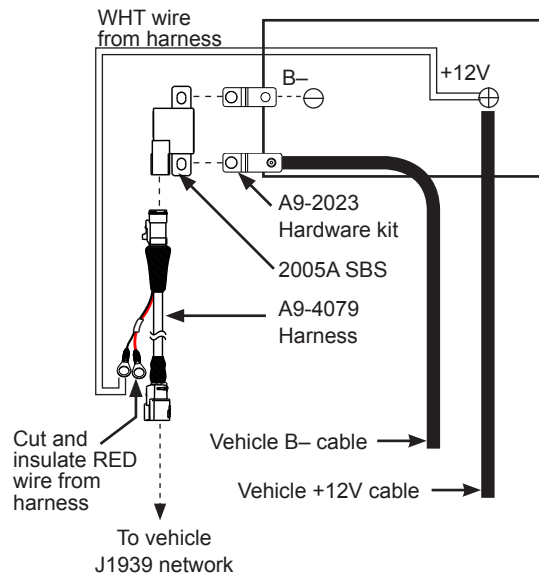

Figure 1: Typical 12V Installation

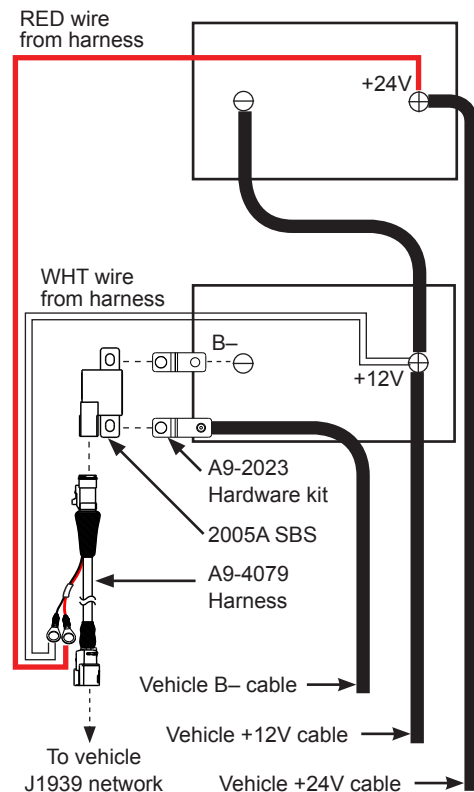

Figure 2: Typical 24V Installation

CAUTION All cables and wires must be supported within 300 mm in (12 in.) of connections to prevent rotation, loosening, and damage to terminals.

Alternate Installation Options

- **For side-post batteries:**

Use one or two links from A9-2023 hardware kit (available separately) if necessary to ensure proper seating of C2005A terminals against battery terminal and vehicle B- cable. See Figure 3 for example.

- **If using an A9-2023 links hardware kit:**

- Fasten small stud of link to appropriate side of C2005A sensor with disc spring washer (beveled side toward sensor terminal) and nut. Torque to 22.5 Nm/200 lb. in. See Figure 4.
- Fasten vehicle B- cable to long stud of link with disc spring washer (beveled side toward cable terminal) and nut. Torque to 22.5 Nm/200 lb. in. See Figure 4.

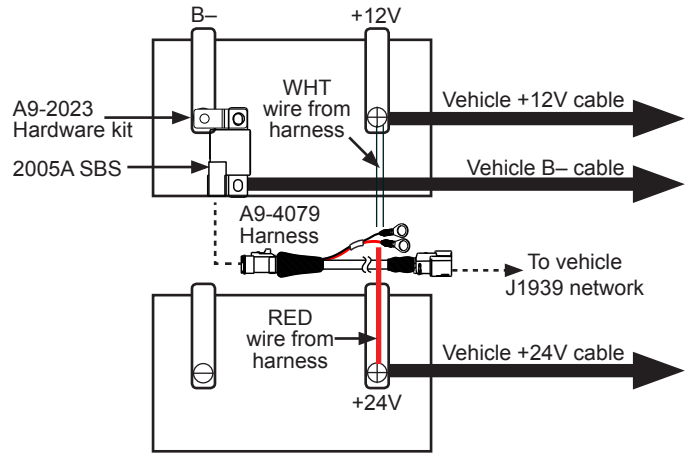

Figure 3: Typical Side-Post Battery Bank Installation

CAUTION

All cables and wires must be supported within 300 mm in (12 in.) of connections to prevent rotation, loosening, and damage to terminals.

- **If using an A9-2034 mounting kit:**

- Open mounting kit cover to expose mounting kit studs. Remove hardware from each stud and retain for B- cable connections.
- Place supplied bus bars on mounting kit studs as shown in Figure 5.
- Install battery B- cable and vehicle B- cable terminals on appropriate mounting kit studs according to markings on C2005 label. Secure with disc spring washers (beveled side facing bus bar) and hex nuts removed in step a. Torque hardware to 12-18 Nm/106-160 lb. in., then close mounting kit cover. See Figure 5.
- Place C2005A sensor terminals over bus bars and align sensor bolt holes in with bolt holes in mounting kit bus bars. Install bolt, disc spring washer (beveled side toward bus bar), and hex nut. Torque to 22.5 Nm/200 lb. in. See Figure 5.
- Secure mounting kit to vehicle by installing two M6 bolts and flat washers (not supplied by CEN). Torque to 5 Nm/45 lb. in.

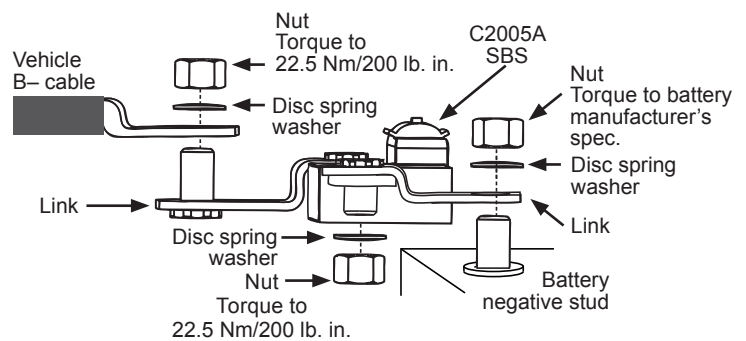

Figure 4: Typical A9-2023 Links Kit Installation

- **Multiple-string battery systems:**

Up to four C2005A sensors can be used in a multiple-string battery system. See Figure 6 on page 3 for an example of a typical multiple-string installation.

NOTICE

When installing a C2005A sensor on systems with more than one battery string, each string must have a sensor with a different suffix; for example, C2005A, C2005B, C2005C, or C2005D (A,B,C, and D suffixes indicate different source addresses). See Figure 6 on page 3.

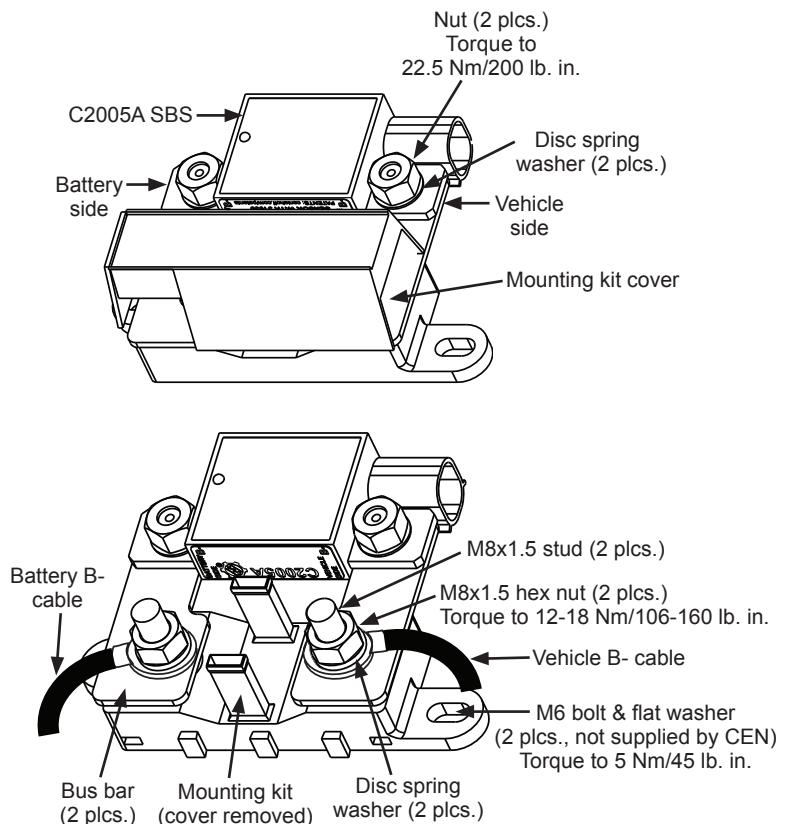

Figure 5: Typical A9-2034 Mounting Kit Installation

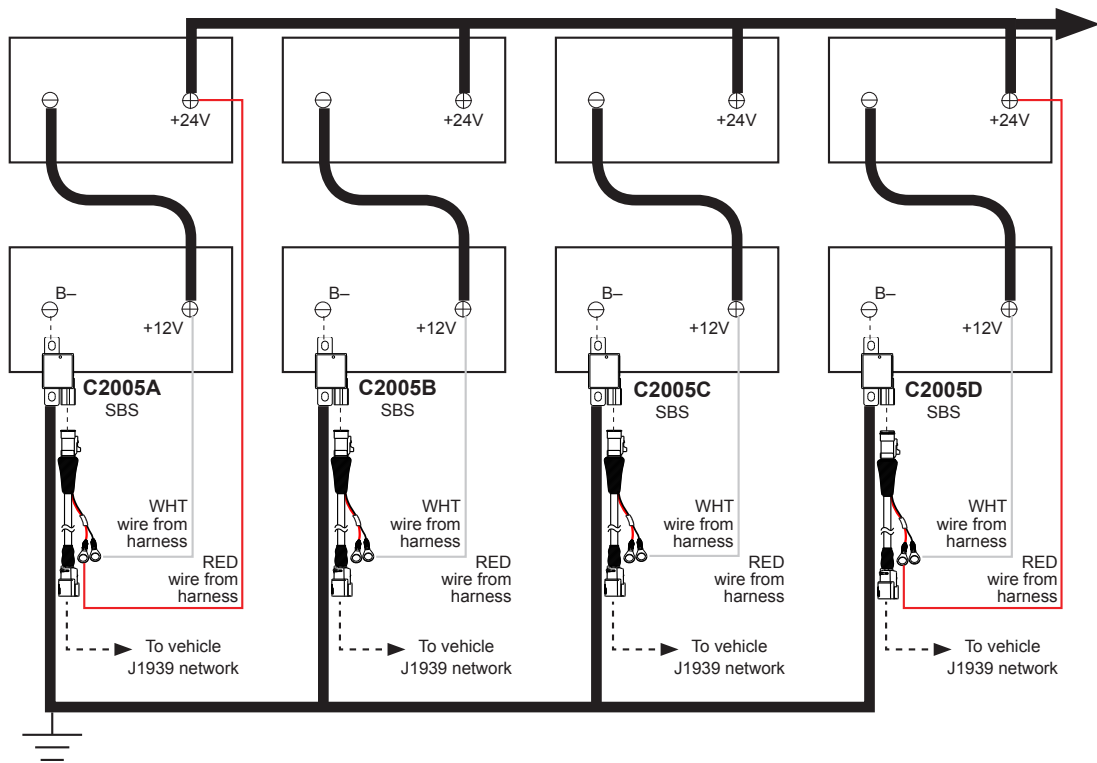

Figure 6: Multiple String Battery Bank

If you have questions about your alternator or any of these instructions, or if you need to locate a Factory authorized Service Distributor, please contact us at:
C.E. Niehoff & Co. • 2021 Lee Street • Evanston, IL 60202 USA
TEL: 800.643.4633 USA and Canada • TEL: 847.866.6030 outside USA and Canada • FAX: 847.492.1242
E-mail us at service@CENiehoff.com