



C851/C851D Alternator OEM Installation Instructions

CEN alternator models C851 (without duct) and C851D (with duct) are cradle mount, negative ground alternators rated at 28 volts/650 amps. To insure proper installation, follow instructions below.

1. Alternators shipped without pulley are shipped with shaft collar, disc spring washer, and nut installed. Remove and discard shaft collar. Make sure Woodruff key is level and securely wedged in slot in shaft.
2. Ensure fan is fully seated and spins freely. Then install pulley and furnished disc spring washer with beveled side facing pulley. Torque pulley nut to 163 Nm/120 lb. ft. See Figure 1.

CAUTION *Do not hammer pulley when installing pulley on shaft. Carefully slip-fit pulley over shaft to prevent woodruff key from moving out of place.*

3. Mount alternator on engine. Use hardened steel washers and 0.5-13 UNC-2B bolts, grade 5 bolts or higher. Torque mounting bolts to 88 Nm/65 lb. ft. or to engine manufacturer's specifications.

CAUTION *Minimum recommended thread engagement is 12.7 mm (0.5") into alternator drive end mounting holes and 16.5 mm (0.65") into anti-drive end mounting holes. Maximum mounting screw depth into alternator regardless of washer and bracket stackup is 18.3 mm (0.72 in.) into drive end mounting holes and 24.1 mm (0.95 in.) into anti-drive end mounting holes. See Figure 1 inset. EXCEEDING MAXIMUM DEPTH WILL RESULT IN IMMEDIATE ALTERNATOR FAILURE.*

4. Install vibration damper bracket on alternator per engine or vehicle manufacturer's instructions if included with alternator and/or required by engine manufacturer.
5. Install cable support bracket(s) on alternator per engine or vehicle manufacturer's instructions if included with alternator and/or required by engine manufacturer.
6. Install drive belt per engine manufacturer's instructions. Typical belt tension is between 80-120 lbs. nominal.
7. Connect vehicle B+ cable to alternator B+ terminal. Install hardware on B+ terminal in stacking order shown in Figure 2. Torque to 30 Nm/22 lb. ft.
8. Connect vehicle B- cable to alternator B- terminal. Install B- hardware in stacking order shown in Figure 3. Torque to 15 Nm/11 lb. ft.

NOTICE *All cables must be supported within 305 mm (12 in.) to prevent twisting, loosening, and damage to terminals.*

9. Install Fresh Air Duct (C851D only) to duct opening on anti-drive end housing. Duct specifications include:
 - 100 mm/4 in. diameter duct no more than 2.5 m/8 ft. long must be used.
 - A maximum of two 90° bends is allowed.
 - Installation must not obstruct airflow.
 - Do not allow moisture, such as rain, road spray, or water used during vehicle cleaning, to be ingested by duct.

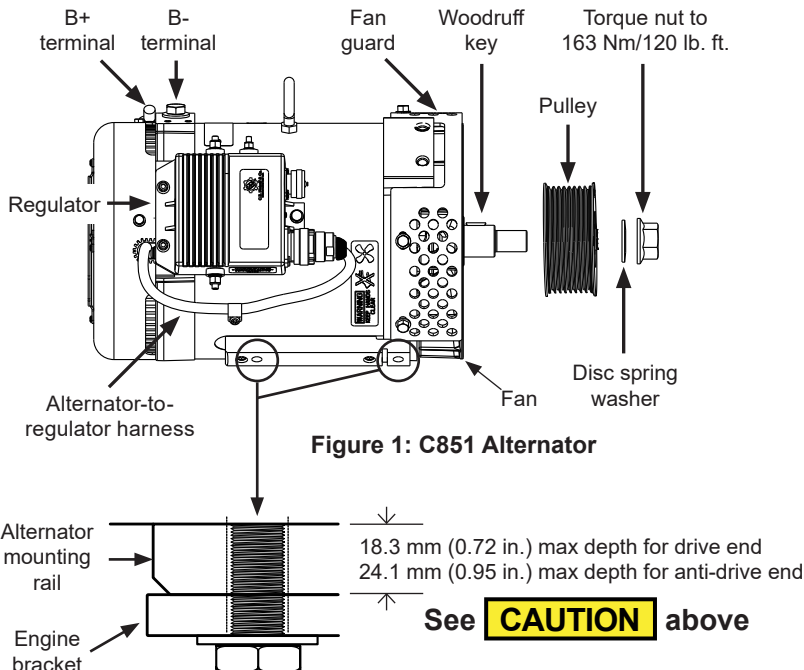

Figure 1: C851 Alternator

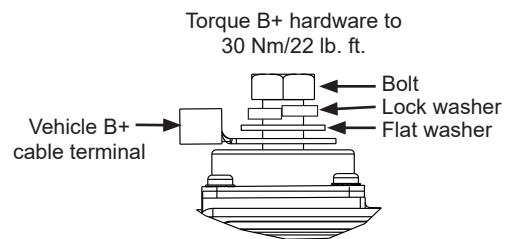

Figure 2: B+ Terminal Hardware Stacking Order

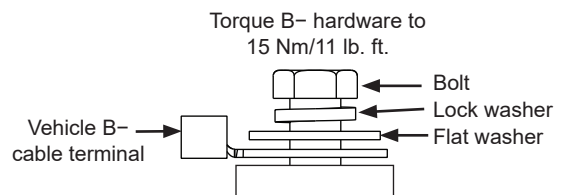

Figure 3: B- Terminal Hardware Stacking Order

CEN Regulator Installation

1. Regulator has four selectable set points. Before installing regulator, verify appropriate switch setting (at bottom of regulator) for your application and change if necessary. See Figure 4 and Table 1 for fixed voltage set point options when used without battery sensor/harness. See Table 2 for battery chemistry-based charge profiles when used with compatible CEN battery sensor/harness. **Contact battery manufacturer or vehicle OEM for charging set point recommendations for your environment or application if necessary.**
2. Mount regulator on alternator with included hardware as shown in Figure 1 on page 1 and Figure 5 below or remotely with extension harness¹. Torque regulator mounting screws to 8.5 Nm/75 lb. in.
3. Plug alternator-to-regulator into receptacle on regulator. See Figure 6 for receptacle location.
4. Connect regulator terminals as required by vehicle:

NOTICE A2-3115 regulator has IGN (pin E), D+ (pin F), and P (pin G) terminal functions built into J1939 temp/voltage sense connector.

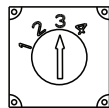

Figure 4: Regulator Voltage Selection Switch

Switch Position	Conventional Regulator Set Point or Smart Series with <u>no Sensor/Harness Connected</u>
1	27.5 V
2	28.0 V
3	28.5 V
4	29.0 V

- Regulator **IGN terminal** (required) must receive voltage from vehicle DC ignition source, typically oil pressure switch or multiplex in order to energize regulator. Torque terminal hardware to 4.5 Nm/40 lb. in. See Figure 6.

NOTICE Voltage should be present at regulator IGN terminal when ignition is on or engine is running. No voltage should be present when ignition is off or engine is not running.

- Regulator **D+ terminal** (if required) provides DC system battery voltage to vehicle (5A maximum) for charge indicator lamp, relay, or multiplex while alternator is producing output. Torque terminal hardware to 4.5 Nm/40 lb. in. See Figure 6.
- Regulator **P/AC/R terminal** (if required) taps AC voltage from alternator, typically half the charge voltage (3A maximum). P/AC/R terminal provides alternator RPM frequency at 10:1 ratio for use with tachometer. Torque terminal hardware to 4.5 Nm/40 lb. in. See Figure 6.

NOTICE If using relay for P/AC/R circuit, coil must be diode-protected and properly rated.

5. If using a J1939/temperature/voltage sense harness, plug harness into J1939 receptacle on regulator. See Figure 6 for receptacle location. Refer to installation instructions included with harness for more information. Harness sold separately².

Switch Position	Battery profile for Smart Series Regulators with <u>Sensor/Harness Connected</u> ²
1	Maintenance (D category)
2	Maintenance-free (Group 31)
3	AGM
4	29.0 fixed

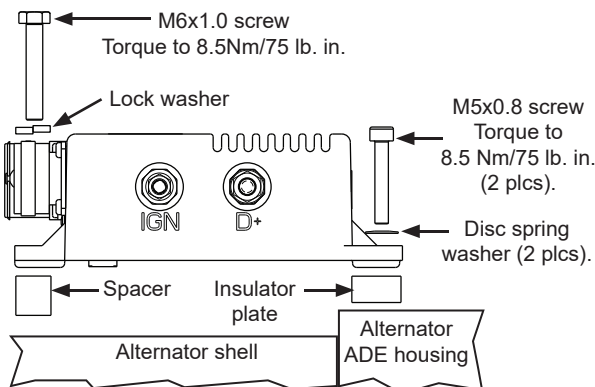

Figure 5: Mounting Regulator

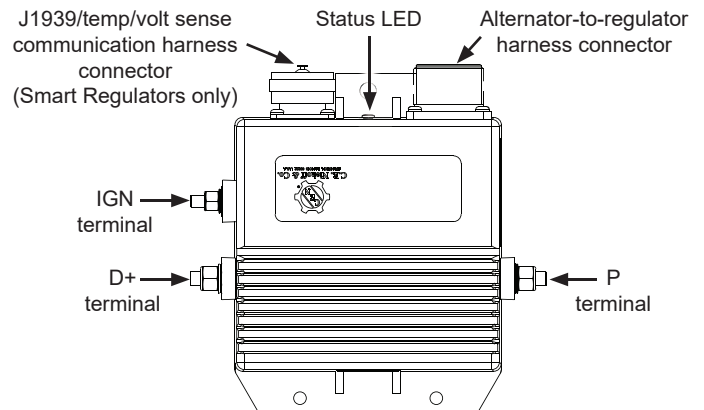

Figure 6: Regulator Connections

1. Contact CEN for regulator extension harness options.
2. Contact CEN for alternative sensor/harness options

If you have questions about your alternator or these instructions, or if you need to locate a Factory Authorized Service Distributor, please contact us at:
 C. E. Niehoff & Co. • 2021 Lee Street • Evanston, IL 60202 USA
 TEL: 800.643.4633 USA and Canada • TEL: 847.866.6030 outside USA and Canada • FAX: 847.492.1242
 E-mail us at service@CENiehoff.com