



OEM Installation Instructions

WARNING This symbol is used to indicate the presence of hazards that can cause severe personal injury or substantial property damage.

CAUTION This symbol is used to indicate the presence of hazards that can cause minor personal injury or property damage.

If an extended wiring harness is supplied with alternator and regulator, see separate instructions packed with harness.

1. A2-330, A2-318, and A2-213 regulators are flat-temperature compensated and are factory-set at lowest setting to accommodate 8D batteries. For other batteries:
 - a. Remove regulator from housing and change position on voltage selector switch. See Table 1 below.

Position		Battery Type
1	27.5V	Maintenance
2	28.0V	Maintenance*
3	28.5V	Maintenance-Free
4	29.0V	Maintenance-Free*

* Use this setpoint to maintain proper battery charge level during shorter operating cycles.

- b. Re-install regulator on drive end housing, and torque mounting screws to 8.5 Nm/75 lb. in.
2. Install alternator:
 - a. Carefully place alternator on alternator mounting bracket.

CAUTION Use caution when lifting alternator to prevent possible minor personal injury. Use hoist along with alternator lifting ring located on top of alternator.

- b. Secure alternator to alternator mounting bracket using four 1/2-13, grade 5 or higher mounting bolts with lock washers. Mounting bolts should extend 17.8/22.7 mm (0.7/0.88 in.) into alternator mounting rail. Torque mounting bolts to 88 Nm/65 lb. ft.
- c. Some alternators are furnished with a vibration dampening bracket (CEN part no. A4-104). Attach one end of bracket to drive end housing and other end to engine. See Figure 1. See engine manufacturer's torque specification for engine gear case bolt torque.

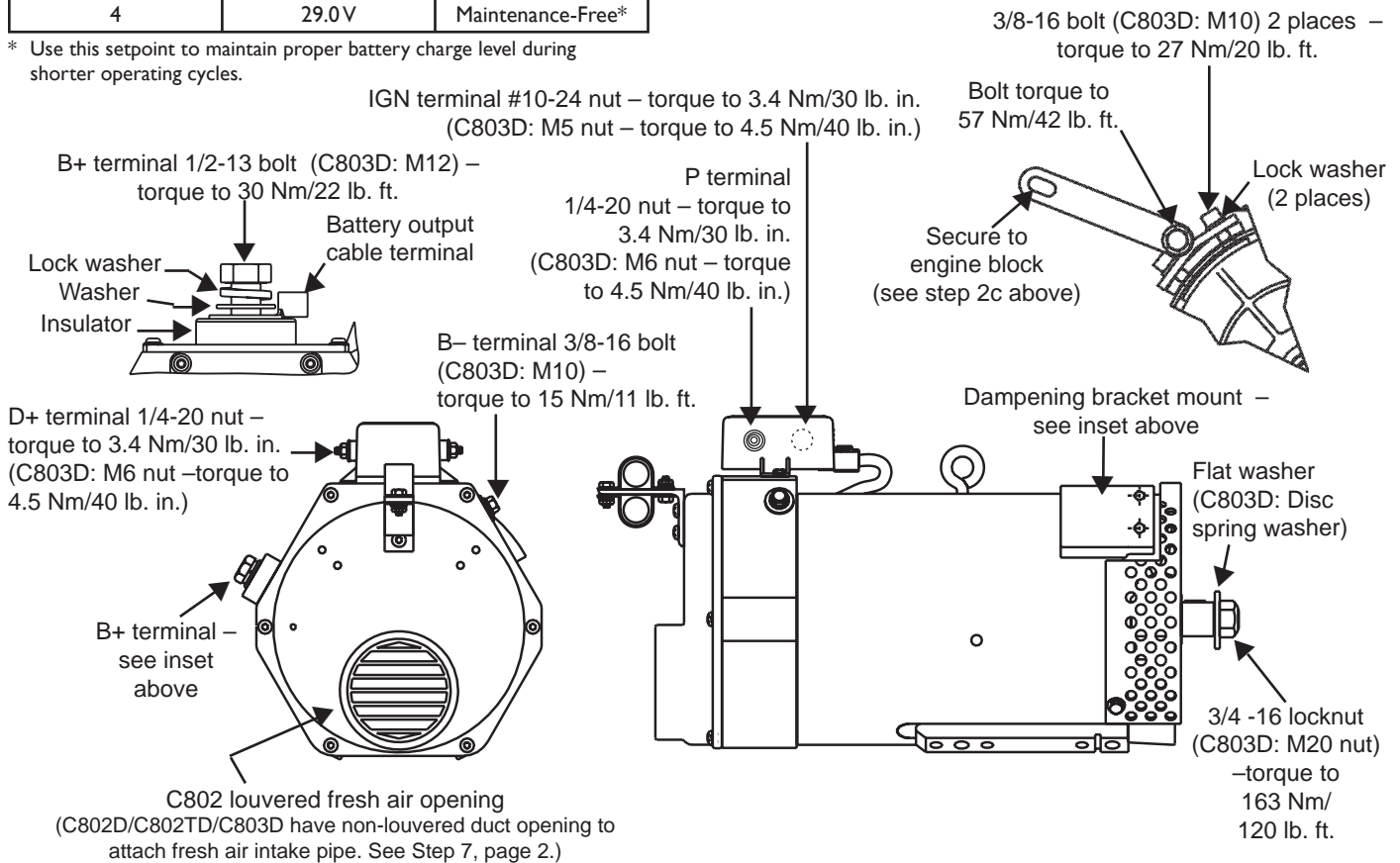

Figure 1 - C802/C802D/C802TD and C803D Alternator Installation Details

3. C802 units are shipped with pulley, flat washer and locknut installed. C803D units are shipped with pulley, disc spring washer, and nut installed. Install alternator drive belt and secure belt tension bracket assembly. Loop alternator drive belt over pulleys and align belt with polyvee grooves.
4. Belt tension guidelines shown below are a starting point for manual and automatic belt tensioners.
 - K-section pulley: 10 grooves minimum, 12 grooves preferred.
 - Belt wrap: 180 degree nominal. Less wrap requires a pulley with more grooves and more belt tension.
 - Belt tension: 100 lbs to 120 lbs nominal. More pulley grooves permit lower belt tension.

For further questions, please contact drive belt manufacturer.

WARNING

Both too low and too high belt tension causes premature bearing failure. Too low belt tension causes belt slip, pulley heating, bearing heating, and ultimately bearing failure. Too high belt tension increases bearing fatigue, resulting in bearing failure.

5. Regulator electrical connections:
 - a. Make sure alternator-to-regulator harness plug is secure in regulator receptacle.
 - b. Connect IGN terminal on regulator to ignition source through oil pressure switch, using proper ring terminal. Torque terminal nut to 3.4 Nm/30 lb. in. (C-803D—torque to 4.5 Nm/40 lb. in.)
 - c. Connect P terminal to tachometer or relay. P terminal taps AC voltage, typically half the charge voltage. Use proper ring terminal. Torque terminal nut to 3.4 Nm/30 lb. in. (C-803D—torque to 4.5 Nm/40 lb. in.)
 - d. D+ terminal provides 28 VDC sense voltage to multiplex controller. When connecting D+ terminal to controller through a relay, the relay coil must be diode protected and rated for proper voltage. Use proper ring terminal. Torque terminal nut to 3.4 Nm/30 lb. in. (C-803D—torque to 4.5 Nm/40 lb. in.)
6. Alternator electrical connections:
 - a. Connect battery positive cable from vehicle to alternator B+ terminal. Torque B+ terminal on alternator to 30 Nm/22 lb. ft. Torque cable clamp hardware to 14 Nm/ 120 lb. in.

CAUTION

B+ cable must be supported by cable clamp within 12" of B+ output terminal to avoid premature failure of B+ output terminal. CEN recommends using cable clamp attached to alternator anti-drive end housing for support.

- b. Connect ground cable from vehicle to alternator B- terminal. Torque B- terminal on alternator to 15 Nm/11 lb. ft.
7. **C802D/C802TD/C803D** alternators only:
 - a. Attach fresh air duct to duct opening on anti-drive end housing.
 - b. Duct specifications include:
 - 100mm/4 in. diameter duct no more than 4 m/13 ft. long must be used.
 - A maximum of two 90° bends is allowed.
 - Installation must not obstruct airflow.
 - Do not allow moisture such as rain, road spray, water used during vehicle cleaning and the like, to be ingested by duct.
 - If a filtered duct will be used, consult filter manufacturer for flow restriction factors.
8. Alternator output test (*conduct test with fully charged batteries*):
 - a. Turn on 28-volt battery system, and start engine.
 - b. Turn on all vehicle loads, including interior/ exterior lights and air conditioning.
 - c. Measure voltage at alternator. Voltage reading should be 27.5 – 28.0 V on low setting of regulator and 28.5 – 29.0 V on high setting. See CEN Troubleshooting Guides for further information.
 - d. Check battery cable voltage drop. There should be no more than 0.4 V drop *on each leg* from alternator to battery.
 - e. Road test vehicle for about 20 minutes.
 - f. Following road test, repeat output test.

CAUTION

Regulators used with these alternators feature overvoltage cutout (OVCO), which disables alternator output in an overvoltage condition. Restarting engine resets OVCO circuit. When an overvoltage condition is no longer present, alternator and regulator should operate normally. Should a no-output condition occur, follow above reset procedure to determine if OVCO trip is the cause.