



**N1224-1 Alternator w/N3229 Regulator;
N1224-2 Alternator w/N3221 Regulator;
N1224-3 Alternator w/N3232 Regulator;
N1224 Alternator
Installation Instructions**

CAUTION

This symbol is used to indicate presence of hazards that can cause minor property damage.

Install alternator as shown in Figure 1:

CAUTION

Slip bushing located in rear mounting foot must be securely tightened against alternator mounting bracket on engine. Failure to do so can result in broken mounting feet or broken upper mounting bracket.

- Units without pulleys are shipped with shaft collar, disc spring washer, and nut. Remove shaft collar. Install pulley (specified by customer), disc spring washer, and nut. Torque nut to 163 Nm/120 lb. ft.
- Use hardened washers between aluminum surfaces and mounting bolt heads and nuts. Torque mounting bolts as shown in Figure 1.

- All cabling, wiring or conduit must be supported within 300 mm/12 in. of termination on alternator.
 - Choose wire gauge for B+ and B- cables capable of handling maximum alternator output with minimum voltage drop.
 - N1224-1/N1224-2/N1224-3: Regulator was shipped as factory-installed on original alternator. If alternator was replaced, re-install regulator on alternator and torque mounting screws to 8.5 Nm/75 lb. in.
- N1224: Install regulator as specified by customer.

14 V B+ terminal stacking order:

- 10 mm x 1.5 bolt
 - disc spring washer
 - customer 14 V output terminal
- Torque to 15 Nm/11 lb. ft.

28 V B+ terminal stacking order:

- 10 mm x 1.5 bolt
- disc spring washer
- customer 28 V output terminal

Torque to 15 Nm/11 lb. ft.

10 mm x 1.5 x 20 mm deep, mounting bolt metric grade 8.8 or higher, torque to 34 Nm/25 lb. ft.

B- terminal stacking order:

- 10 mm x 1.5 bolt
 - disc spring washer
 - flat washer
 - customer ground terminal
- Torque to 15 Nm/11 lb. ft.

AC terminal stacking order:

- 6 mm nut
 - disc spring washer
 - customer specified terminal
- Torque to 3.4 Nm/30 lb. in.

E terminal stacking order:

- 5 mm nut
 - disc spring washer
 - customer specified terminal
- Torque to 3.4 Nm/30 lb. in.

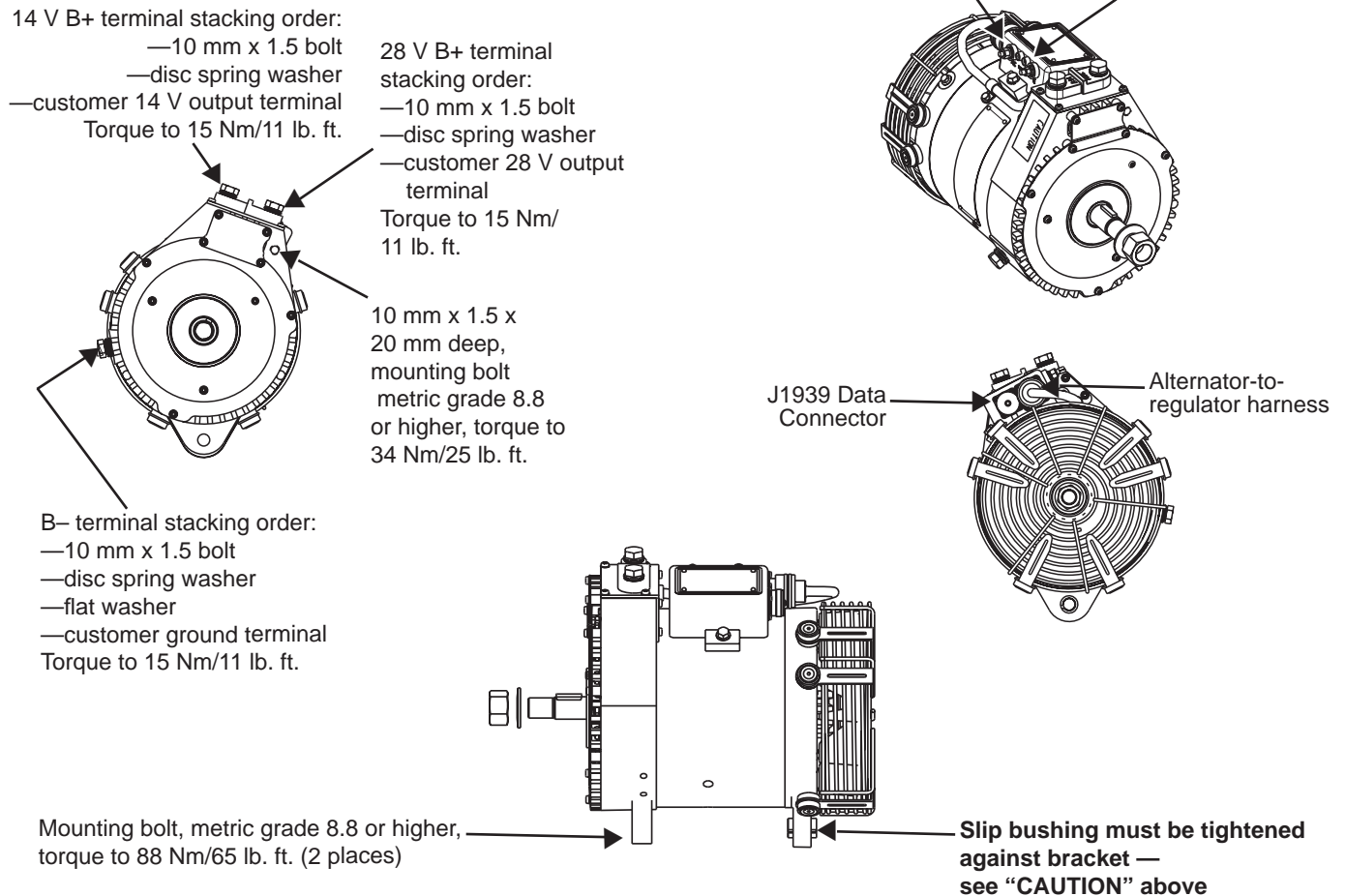

Figure 1 - N1224/N1224-1/N1224-2/N1224-3 Alternator Installation Details